





VERTILINA HYBRID

Handleiding - Manuel - Anleitung - Manual



CONTENT

31. General information.....	46
32. Product description	47
33. Dimensions	48
34. Installation	49
34.1. Tools.....	49
34.2. Coupling nut installation.....	51
35. JDPC Sturingen.....	52
36. Quick Guides	52
36.1. Control D01 - TPT.....	52
36.2. Control D09 - ACO.....	52
37. Electrical connection	53
37.1. Control D01 - TPT.....	53
36.3. Control D03 - BMS	53
37.2. Control D09 - ACO.....	54
38. Control.....	55
38.1. Control D01 - TPT.....	55
38.2. Control D09 - ACO.....	56
39. Settings via circuit board controller - All controls	57
39.1. Adjusting the water temperature.....	57
39.2. Setting fanspeed.....	57
39.3. Switch on/off window contact.....	57
39.4. Circuit board error code.....	57
39.5. Factory reset	57
40. Warranty conditions.....	58

<p>CEO JAGA N.V. Jan Battheu</p>  <p>30/01/2026</p>	<p>DECLARATION OF CONFORMITY</p> <p>JAGA N.V. - Verbindingslaan 16 - B 3590, declares under its sole responsibility that the product to which this declaration relates: Vertilina Hybrid is in conformity with the following standards or documents provided that these are used in accordance with our instructions: EN 60335-1:2012 + A11:2014 + A12:2017 + A13:2017 + A1:2019 + A2:2019 + A14:2019 + A15:2021 + A16:2023 NBN EN IEC 60335-2-80 based on EN IEC 60335-2-80:2024 + A11:2024</p> <p>Following the provision of Directives as amended: - Low Voltage 2014/35/EC - EMC 2014/30/EC - Machinery 2006/42/EC - RoHS 2011/65/EU</p>	 
--	--	---



IMPORTANT INFO

The unit must be installed by a certified installer in accordance with the installation instructions and the local building codes. Please follow this instruction manual and file it somewhere safe! The unit must always be accessible for maintenance and inspection..

This appliance must not be used by children under 8 years of age or by persons with reduced physical, sensory or mental capabilities, or lack of experience and knowledge, unless they are supervised or have been instructed in the safe use of the appliance and understand the hazards involved.

The warranty is void when:

- The installation, maintenance or operation instructions in this manual are not respected.
 - The initial start-up has been carried out before a general cleaning of both the fan and the coil.
 - Modifications have been made to the product, before, during or after product installation.
 - Maintenance has been carried out by unauthorized people.
 - Access to the unit has been restricted due to on-site conditions.
- This device is covered by the general warranty conditions of Jaga NV.

For general safety information see: <https://jaga.com/ex/provisions/>





PRODUCT REMOVAL INSTRUCTIONS

The symbol of a crossed-out trash bin on your product is a reminder that, within the European Union, all electrical and electronic products must be collected separately at the end of their life cycle. Do not dispose of these products with unsorted waste. Bring these products to a waste collection point to prevent uncontrolled waste disposal (harmful to the environment and health) and to promote sustainable use of materials. For more information on waste disposal, you can contact product suppliers, local waste authorities, or relevant national manufacturers.

The manufacturer disclaims all liability and responsibility regarding any inaccuracies in this document due to printing or translation errors. The manufacturer reserves the right to make changes deemed necessary or useful. This document or parts of this document may not be copied, modified, or reproduced without the written permission of Jaga NV.

31. GENERAL INFORMATION

31.1. INSTALLATION

- Check for any visible damage.
- Installation must be carried out by certified technicians. Incorrect installation could cause product failure, a reduced performance or an increased noise level.
- Check for any visible damage.
-  The unit might have sharp edges; use gloves during installation/adjustment.
- The unit must remain accessible for inspection and maintenance, the trench must be removable at all times.
-  Always disconnect and switch off the power supply during installation or maintenance.
- The unit must be handled with care in order to avoid damage to the unit's interior and exterior parts.
- Mount the device in a solid and stable location to prevent vibrations from being transmitted between different components. Provide contact sound insulation if necessary.
- Install this product in an environment with a temperature between 5 °C and 70 °C.
- Install this product in an environment with a relative humidity of less than 90%.
- all clearances indicated in the manual must be respected in order to guarantee performance, and to allow installation and maintenance.
- Do not place any objects on the unit.
-  Do not insert objects into the supply and return air openings.
- With cooling: insulate the hydronic pipes.
- When the condensate drain pipes are being connected, the pipe system must be sufficiently supported in order to prevent strain on the condensate drain tray.

31.2. OPERATIONAL LIMITS

Installation that does not comply with the specified operational limits relieves Jaga NV from discharge liabilities with regard to damage to objects and persons.

- MAXIMUM WATER TEMPERATURE: 90°C
- Maximum coil pressure: 10 bars.
- SUPPLY VOLTAGE: 230 VAC

31.3. THE UNITS COMPLY WITH THE FOLLOWING GUIDELINES

2006/42/EC Machinery Directive

31.3.1. Terms of use:

The appliance must not be installed (standard IEC EN 60335-2-40):

- Outside
- In areas subject to frost
- IN HUMID ROOMS (ex.. bathroom)
- In areas where there is a risk of explosion due to gases, vapors, or dust

31.3.2. Device installation guidelines:

- Do not insert objects into the supply and return air openings.

31.4. USE

- This appliance is not intended for use by persons (including children) with reduced physical, sensory, or mental capabilities, or lack of experience and knowledge, unless they are supervised or instructed by a person responsible for their safety on how to use the appliance.
- Children shall not play with the appliance.
- Be sure to read the instruction manual carefully.
- The area must be dry and dust-free, with a temperature between 5°C and 70°C and a relative humidity < 90%. (norm IEC EN 60335-2-40).
- The unit has been designed to function as a fan coil for both heating and cooling applications; any other use is strictly forbidden. Installing the unit in an explosive environment is prohibited.
- The unit is not intended for industrial applications.

31.5. MAINTENANCE

- The unit must remain accessible for inspection and maintenance, the trench must be removable at all times. Do not place any objects on or in front of the device. Always switch off and disconnect the power before installing or servicing the device.
- Maintenance of the device is very important for its proper operation. This should be carried out regularly according to the usage and function of the room in which the device is installed
- Maintenance must be carried out by qualified technicians.
- Only use original parts.
- A dirty grille obstructs the air flow, so clean the grille at regular intervals, depending on the room's purpose and how it's used. The grille should never be disassembled for maintenance and can be easily cleaned by using a vacuum cleaner.
- Only use original parts.
- Every 6 months: Check the condition of the coil and condensate drain.
- Do not use any solvent or cleaning agent based products.
-  Do not insert objects into the supply and return air openings.

31.6. STARTING

 Start-up and commissioning of the fancoil must be carried out by skilled staff, qualified to work on this type of product. Check beforehand whether:

- The unit is positioned correctly.
- The supply and return pipes are properly connected and insulated.
- The pipes are clean and air is removed.
- The inclination of the unit towards the drain and the p-trap are correct.
- The wiring connections are correct and properly tightened.
- The supply voltage is correct.



 **Let the device run at the highest setting for at least 3 hours and check for any irregularities.**

31.7. DISASSEMBLY

- When the unit is not used for long periods of time, it must be disconnected from the mains electrical connection.
This can be done by setting the power switch to the OFF position.
-  When the unit is not used for long periods of time, it must be disconnected from the mains electrical connection. If the unit is not used during the winter period, the water in the system may freeze. A suitable quantity of anti-freeze liquid should be mixed with the water. Mixing the water with glycol modifies the unit's performance. Pay attention to the safety instructions on the packaging regarding glycol.

31.8. PACKAGE & ENVIRONMENT









31.8.1. Follow the instructions:

- Check for any visible damage
- open the packaging
-  Remove the packaging material and put it in the appropriate collection point or recycling facility, in compliance with the local regulations.
-  Do not leave the packaging within reach of children.

31.8.2. Protect the environment:

Remove the packaging materials in accordance with the applicable national or local regulations.

31.9. SYMBOLS

-  Danger
-  Danger: electrical hazard
-  Danger: sharp edges / components
-  Danger: hot surfaces
-  Danger: moving parts
-  Attention: important warning
-  Environmental safeguard
-  VDC - direct current
-  VAC - alternating current

32. PRODUCT DESCRIPTION



33. DIMENSIONS

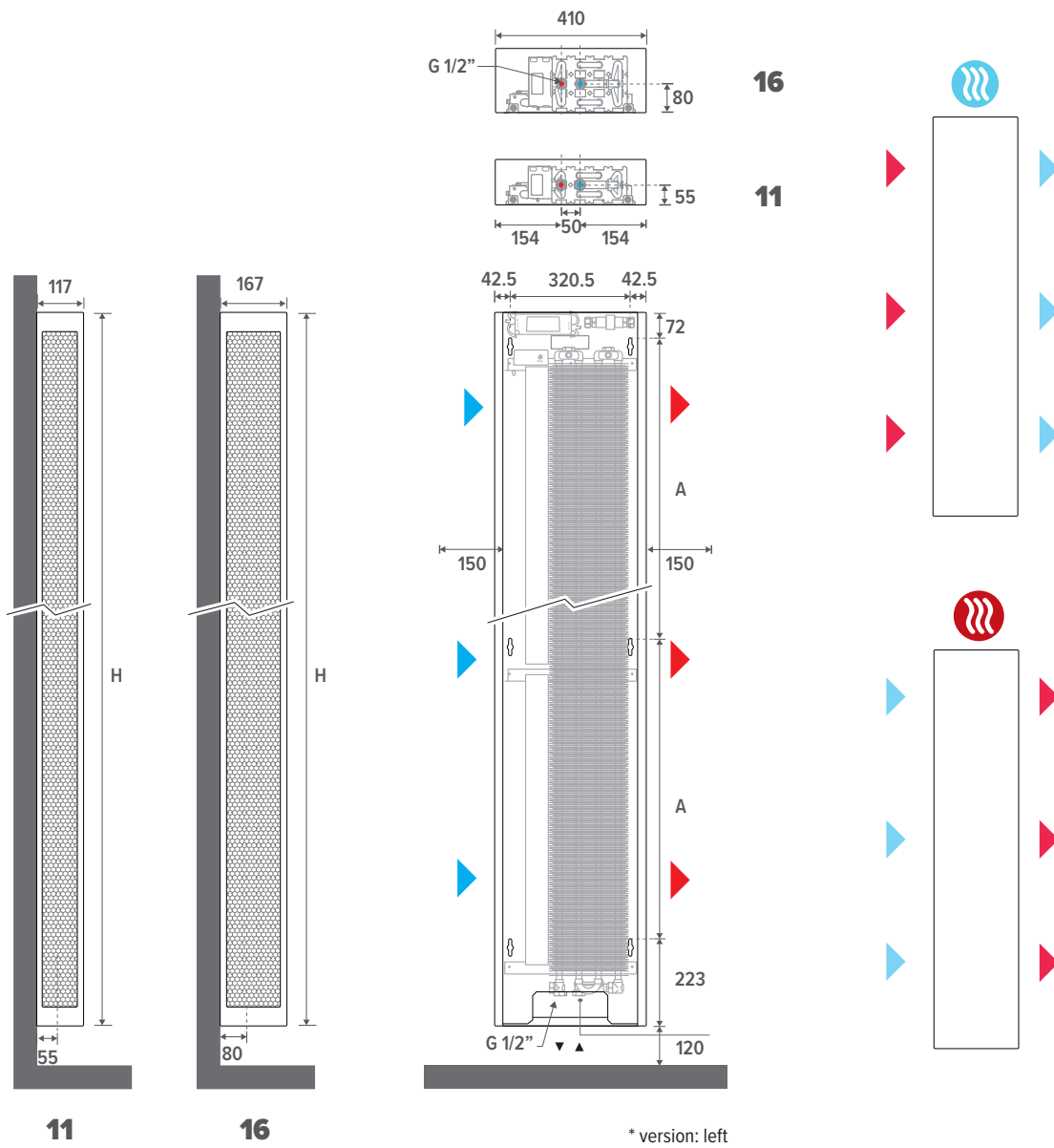

H	900	1000	1200	1500	1900	2100	2300	2500	2700	2900
A	700	900	600	700	800	900	1000	1100	1200	1300

Dimensions in mm

34. INSTALLATION

34.1. TOOLS



5 & 12



26 & 30



01 - ALL CONTROLS

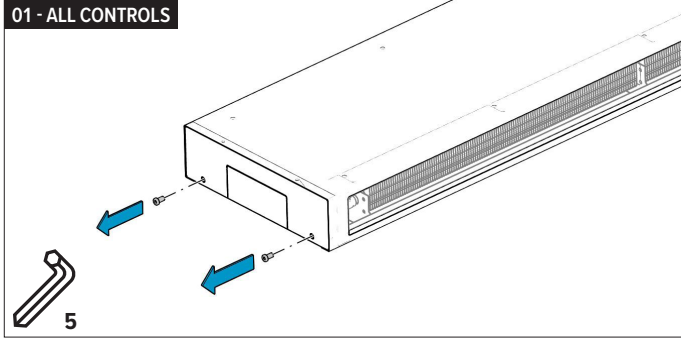

02 - ALL CONTROLS

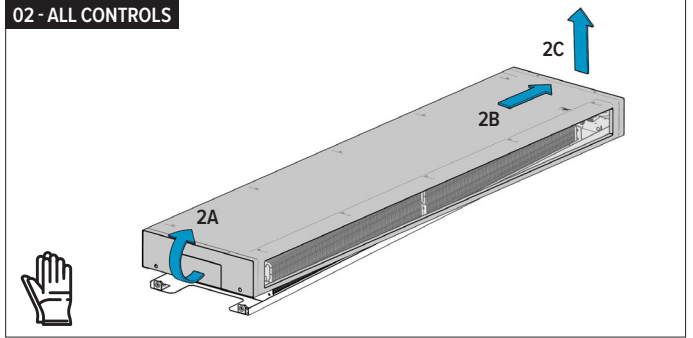

03 - D01 - TPT / D03 - BMS

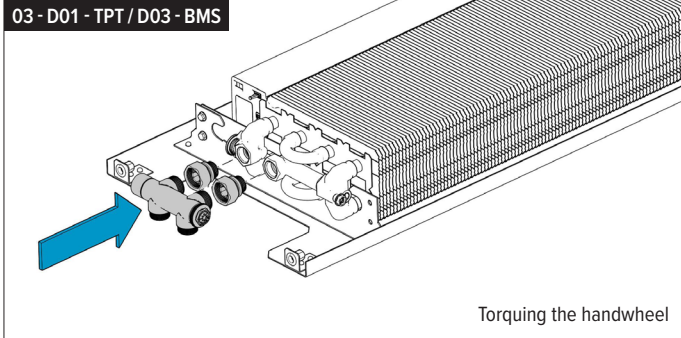

Torquing the handwheel

03A - D09 - ACO

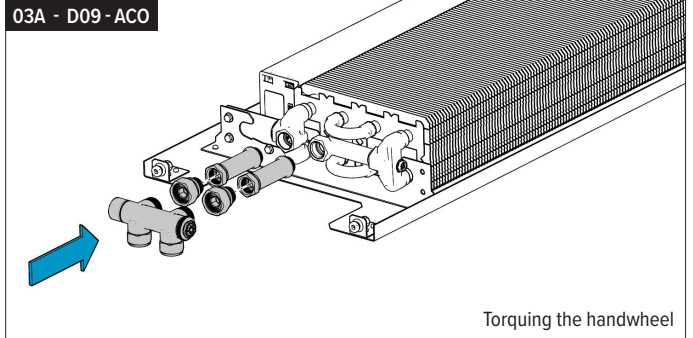

Torquing the handwheel

04 - D01 - TPT / D03 - BMS

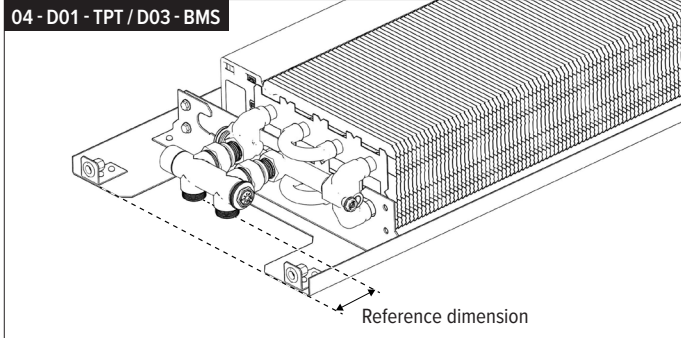

Reference dimension

04A - D09 - ACO

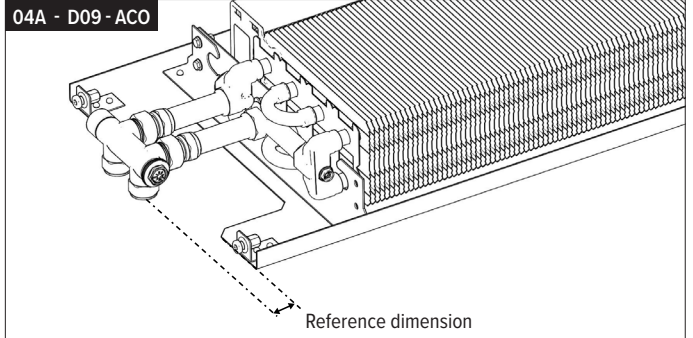

Reference dimension

05 - D01 - TPT / D03 - BMS

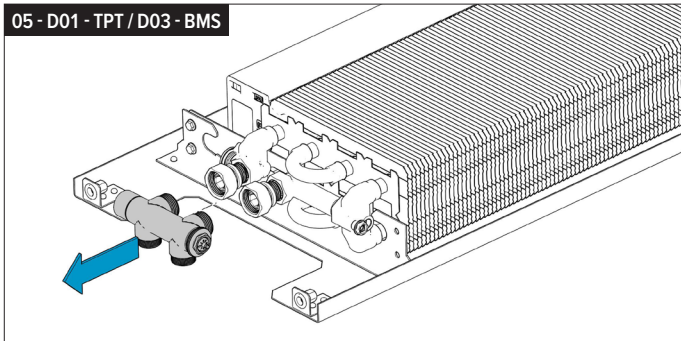

05A - D09 - ACO

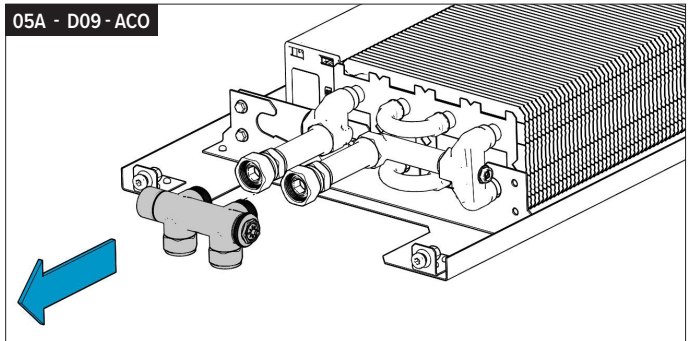

06 - D01 - TPT / D03 - BMS

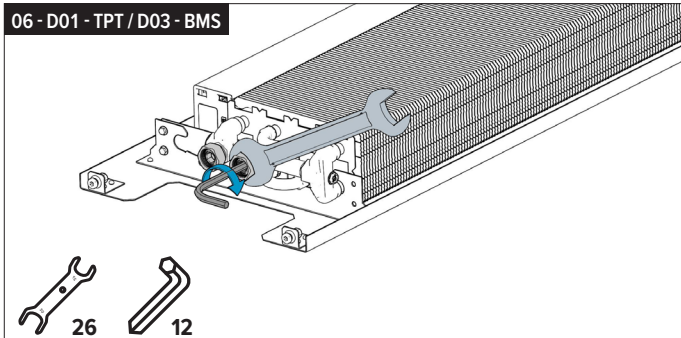

06A - D09 - ACO

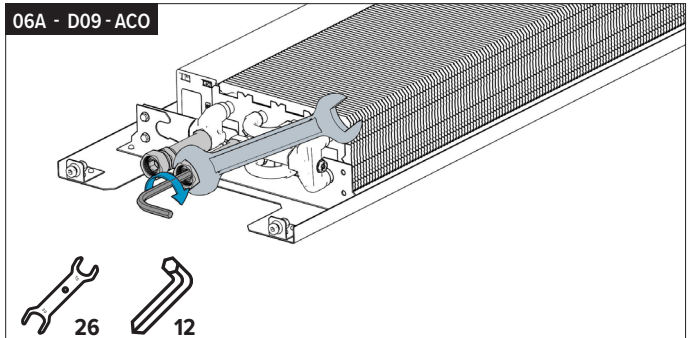

07 - ALL CONTROLS

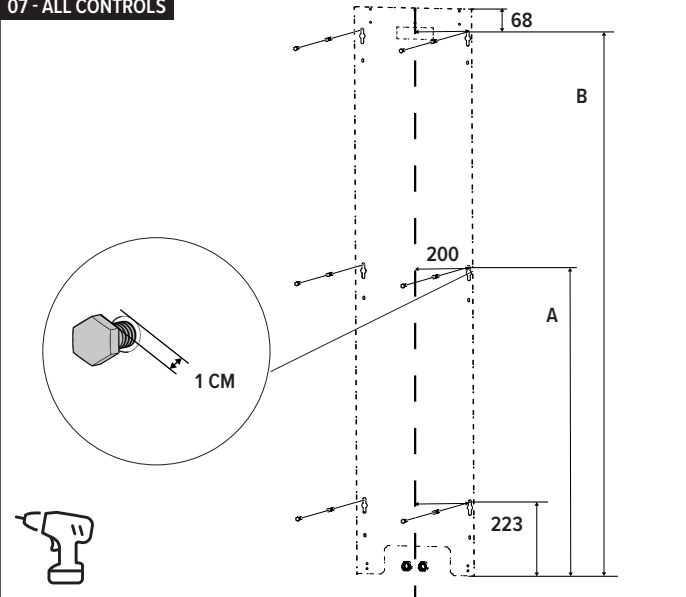

TYPE	A	B	TYPE	A	B
70	623	1023	190	1023	1823
90	823	1423	210	1132	2023
100	923	1623	230	1232	2232
120	1123	2023	250	1323	2423
150	823	1423	270	1423	2623
170	923	1623	290	1523	2823

08 - ALL CONTROLS

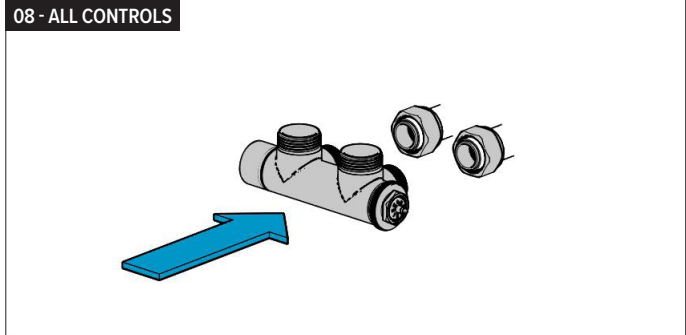

09 - ALL CONTROLS

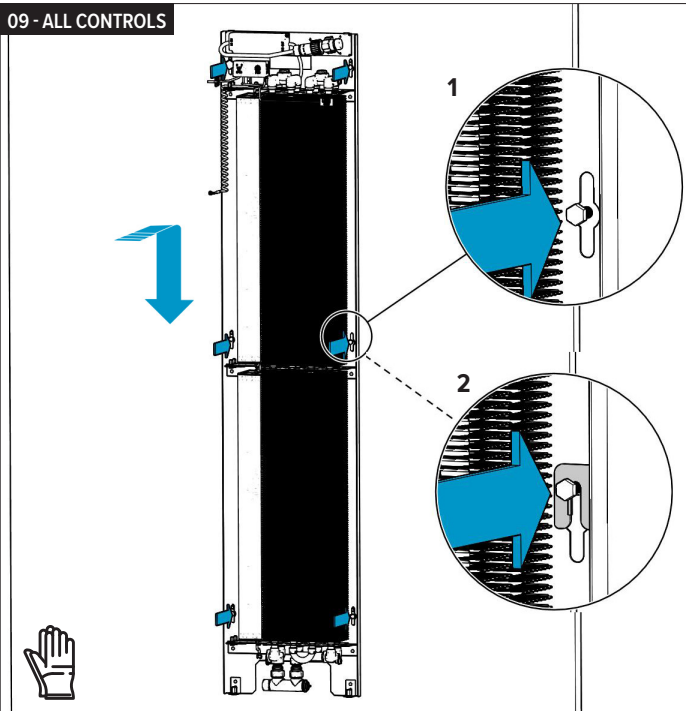

10 - D01 - TPT / D03 - BMS

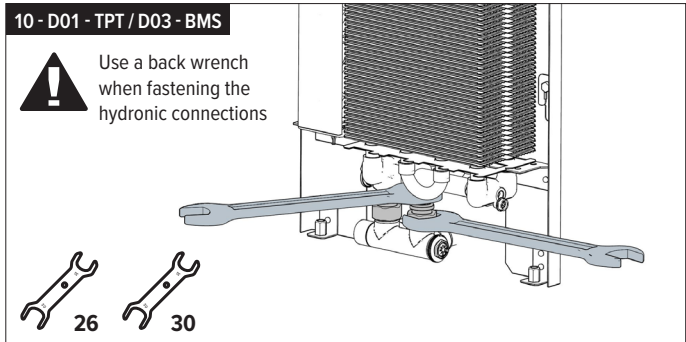

10A - D09 - ACO

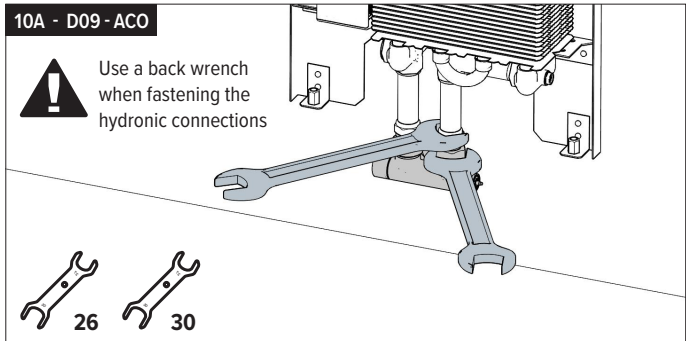

11 - D01 - TPT / D03 - BMS

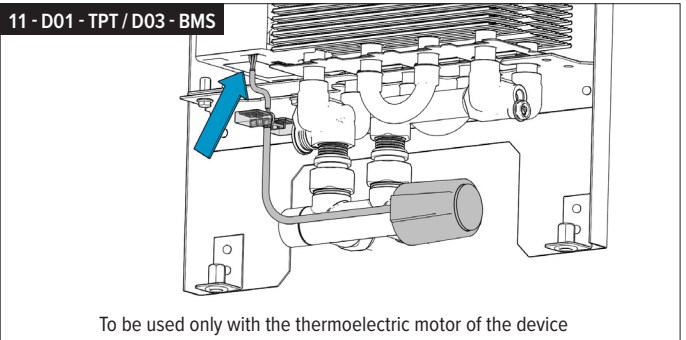

11A - D09 - ACO

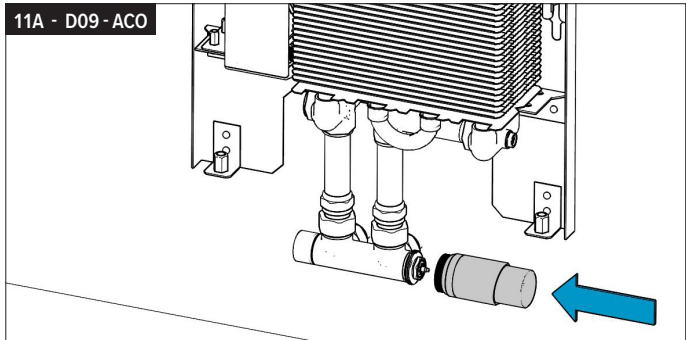

EN

12 - ALL CONTROLS

De-aerate the circuit and check for leaks.

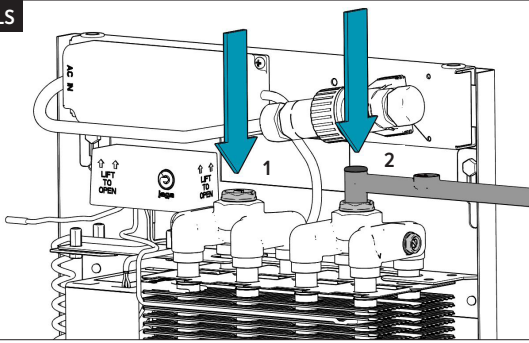

13 - ALL CONTROLS

See: Electrical connection

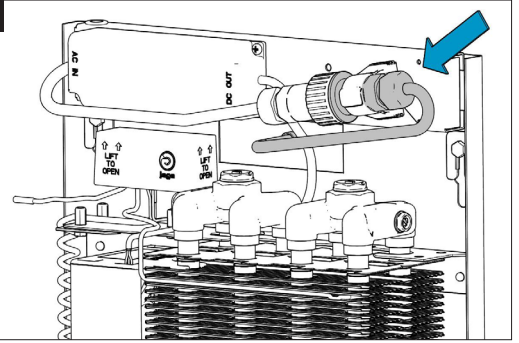

14 - D01 - TPT / D09 - ACO

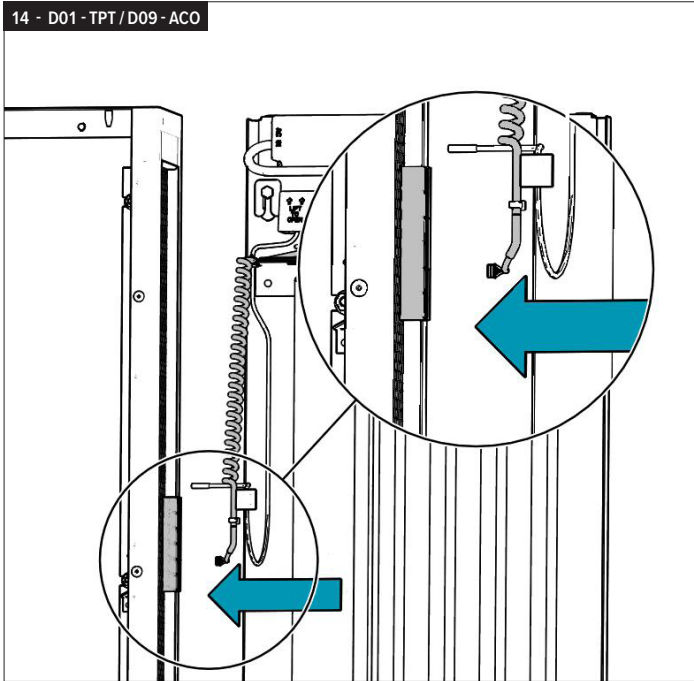

15 - ALL CONTROLS

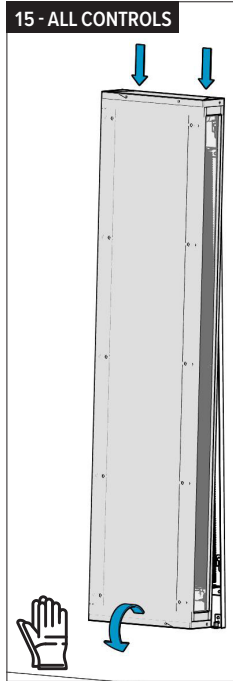

16 - ALL CONTROLS

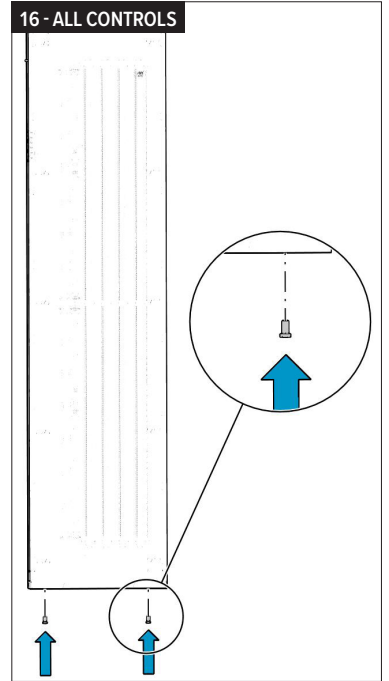

34.2. COUPLING NUT INSTALLATION

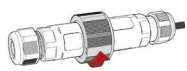

Unlock the connecting part.

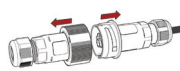

Pull the 2 parts apart.

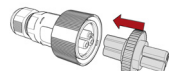

Place the tool on the connection core.

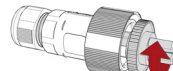

Turn the core.

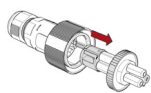

Remove the core from the housing.

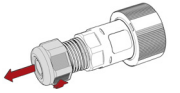

Loosen the cable gland.

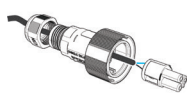

Insert the cable through the cable gland up to the core.



Connect the cables correctly to the core.

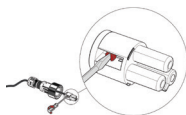

Fix the cables by tightening the screw.

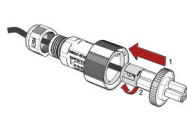

Slide the core into the housing and tighten it.

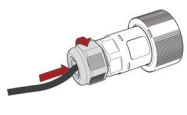

Fix the cable gland.

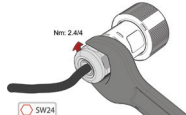

Tighten the cable gland with 2,4/4 Nm.

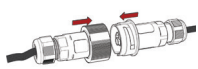



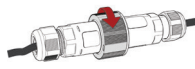



Place the 2 sides together.



Tighten the connecting part.

35. JDPC STURINGEN

CONTROL	POSITION	CONTROL PANEL	EXTERNAL 0-10 V CONTROL	WATER TEMPERATURE SENSOR	AIR TEMPERATURE SENSOR
D01 - TPT	 	✓	-	✓	✓
D03 - BMS	 	-	✓	✓	-
D09 - ACO	 	✓	-	✓	✓

36. QUICK GUIDES

36.1. CONTROL D01 - TPT

QUICK GUIDE

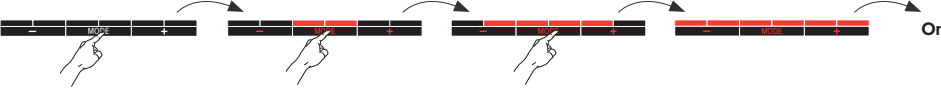

On















 $T_{set} < T_k$
 $T_w < 24\text{ }^\circ\text{C}$

 $T_w > 28\text{ }^\circ\text{C}$
 $T_{set} > T_k$

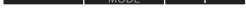

TEMPERATURE

		
26°C		16°C
24°C		18°C
23°C		19°C
22°C		20°C
21.5°C		20.5°C
21°C		21°C
20.5°C		21.5°C
20°C		22°C
19°C		23°C
18°C		24°C
16°C		26°C

36.2. CONTROL D09 - ACO

QUICK GUIDE

ON

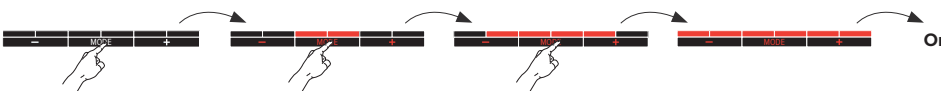

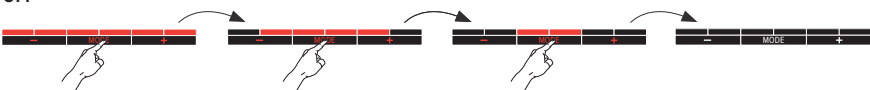

On

OFF



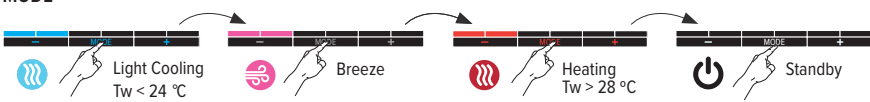

MODE



 **Light Cooling**
 $T_w < 24\text{ }^\circ\text{C}$

 **Breeze**

 **Heating**
 $T_w > 28\text{ }^\circ\text{C}$

 **Standby**

SPEED

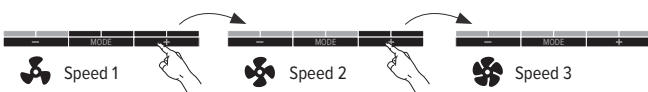

 **Speed 1**

 **Speed 2**

 **Speed 3**

37. ELECTRICAL CONNECTION

37.1. CONTROL D01 - TPT

Upon recognising the correct water temperature, the fan will modulate depending on the difference between the measured room temperature and the desired room temperature.

$T_w > 28^\circ\text{C}$ $T_w < 24^\circ\text{C}$

The user chooses the desired room temperature on the control panel in heating or cooling. The thermoelectric valve will stay open until the room temperature is reached.

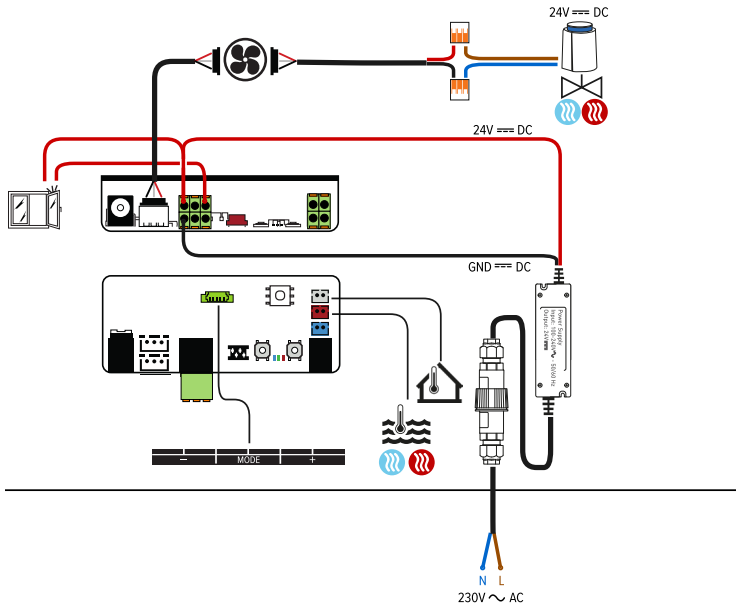

36.3. CONTROL D03 - BMS

When heat or cold is requested, a BMS/home automation system or JAGA thermostat will send a 0-10 V signal. When detecting cold or hot water, the fan will rotate proportionally to the 0-10 V signal.

$T_w > 28^\circ\text{C}$ $T_w < 24^\circ\text{C}$

Optional:

The thermoelectric valve will open as soon as the incoming command signal $> 1.5\text{ V}$.
The thermoelectric valve closes as soon as the incoming command signal $< 0.5\text{ V}$.

Optional:

When heat or cold is requested, a BMS/home automation system or JAGA thermostat will open the thermoelectric valve.

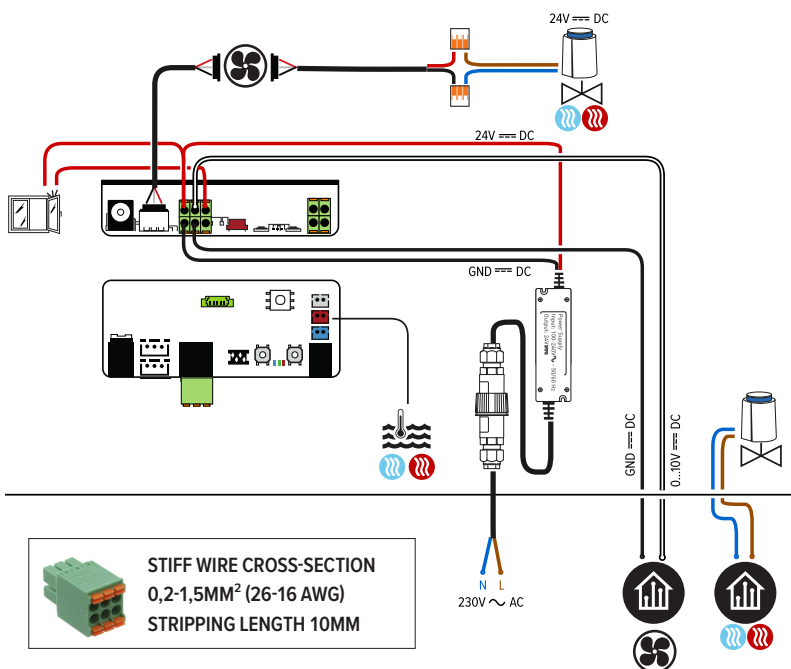



37.2. CONTROL D09 - ACO

The unit automatically switches to the heating mode as soon as the water temperature is higher than 28°C and 4°C higher than the room temperature. The unit will start at the speed last selected (1, 2 or 3). When one of the two conditions is no longer met, the unit automatically returns to standby.

The unit automatically switches to the cooling mode as soon as the water temperature is lower than 18°C and 2°C lower than the room temperature. The unit will start at the speed last selected (1, 2 or 3). When one of the two conditions is no longer met, the unit automatically returns to standby.

The breeze mode is manually switched on or off, regardless of water temperature. As long as the breeze mode is active, the auto-changeover is deactivated.

 $T_w > 28^{\circ}\text{C}$

 $T_w < 24^{\circ}\text{C}$

 $T_w \leq /$

Optional:



When heat or cold are requested, a BMS/home automation system will open up the thermoelectric valve.

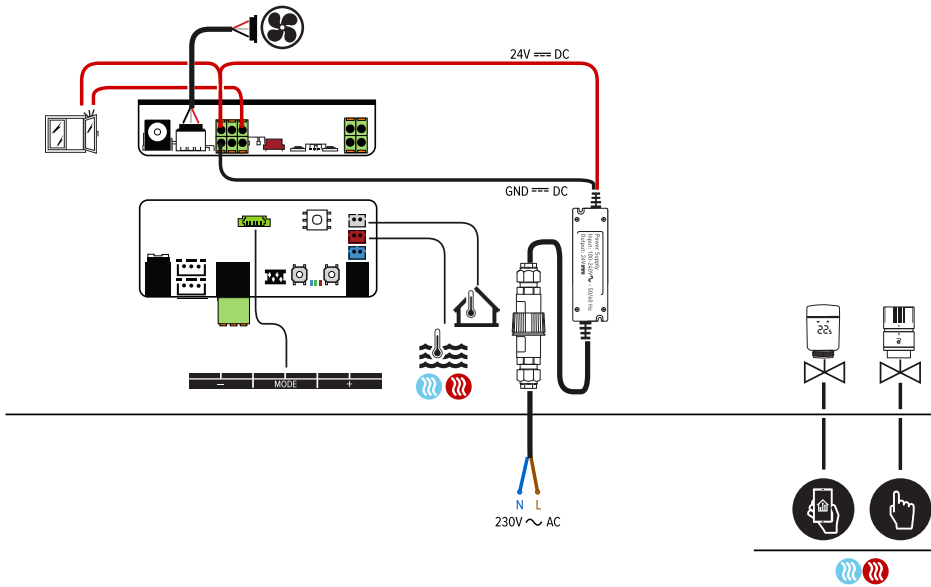

38. CONTROL

38.1. CONTROL D01 - TPT

The default setting of this unit is cooling condensation (deep cooling). If you only wish to cool non-condensing (light cooling), then you need to adjust the water temperature setting to 24°C.



The user sets the desired room temperature via the [-] and [+] button



The unit starts as soon as the control panel is in cooling mode, the desired room temperature has not been reached and the water temperature is < 18°C.



The unit starts as soon as the control panel is in heating mode, the desired room temperature has not been reached and the water temperature is > 28°C.

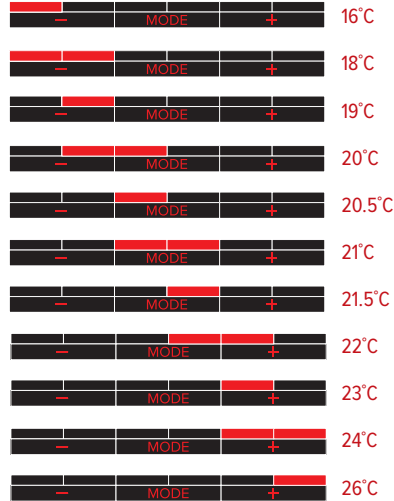
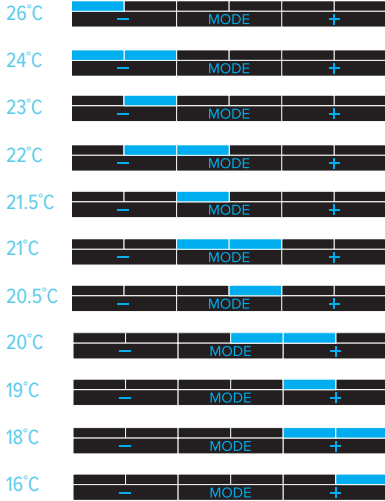

The speed is controlled automatically and the max speed corresponds to 30 dB(A).

Boost function: The unit runs at maximum speed for 15 minutes. The LED's are flashing slowly.



Deactivating

Briefly press the [+] button. After 30 seconds, this is automatically saved and the device returns to the selected mode.

⚠ De boost mode automatically stops when the water temperature is < 18°C when cooling or > 28°C when heating.

38.1.1. Notifications

- ⚠ Blue LEDs are flashing: the water temperature for cooling is too high**
- ⚠ Red LEDs are flashing: the water temperature for heating is too low**

Control panel error codes

LED flashes rapidly in the color of the set mode.



Error sensor - Check the water temperature sensor



Error sensor - Check the room temperature sensor

The LEDs are blinking in a pattern and in the color that matches the selected mode

Only if the window contact is connected and switched on: The window contact is open.



38.1.2. Soft reset

If the unit does not respond as expected, you can perform a soft reset. This resets all measured and calculated values in the controller and restarts the unit. The customised settings are retained.

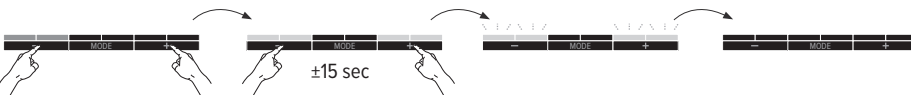

- Put the unit in any mode.
- Press and hold the [-] and [+] simultaneously until the first 2 and the last 2 LEDs start flashing.
- Release the [-] and [+].
- The orange, blue and green lights will illuminate successively, the unit will reset and reboot.

38.2. CONTROL D09 - ACO

Switch on the device: Hold down [Mode] for 10 seconds until all LEDs are on.

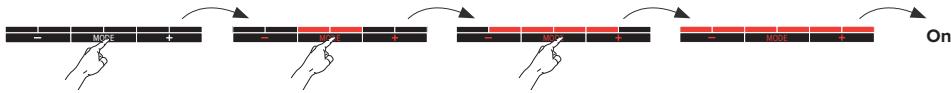

Mode: The device is controlled via auto-change-over. The user can temporarily select another mode manually.

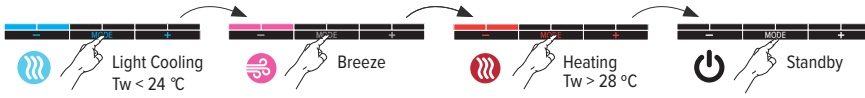

Speed:

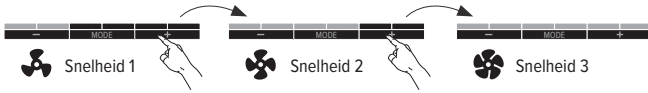

Permanently off: All functions are disabled until the user switches on the unit via the control panel. Hold down [Mode] until all LEDs are off.

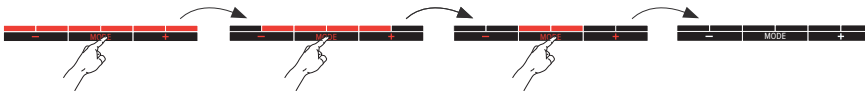

38.2.1. Notifications

Blue LEDs are flashing: the water temperature for cooling is too high
Red LEDs are flashing: the water temperature for heating is too low

Control panel error codes

LED flashes rapidly in the color of the set mode.

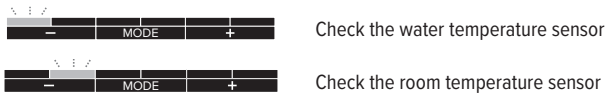

The LEDs are blinking in a pattern and in the color that matches the selected mode
 Only if the window contact is connected and switched on: The window contact is open.



38.2.2. Soft reset

If the unit does not respond as expected, you can perform a soft reset. This resets all measured and calculated values in the controller and restarts the unit. The customised settings are retained.

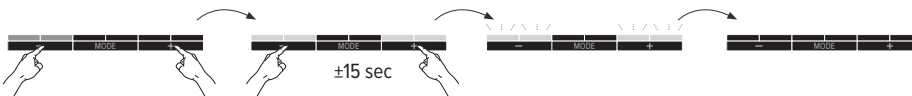

1. Put the unit in any mode.
2. Press and hold the [-] and [+] simultaneously until the first 2 and the last 2 LEDs start flashing.
3. Release the [-] and [+].
4. The orange, blue and green lights will illuminate successively, the unit will reset and reboot.

39. SETTINGS VIA CIRCUIT BOARD CONTROLLER - ALL CONTROLS

39.1. ADJUSTING THE WATER TEMPERATURE

39.1.1. Adjusting the maximum water temperature for cooling

By reducing the water temperature setting, the unit will start later. If the water temperature is set higher, the unit will start sooner.

1. Start setup mode: press and hold the [-] button until the blue LED flashes 5x and release.
2. Short press the [-] or [+] button to adjust the set temperature.

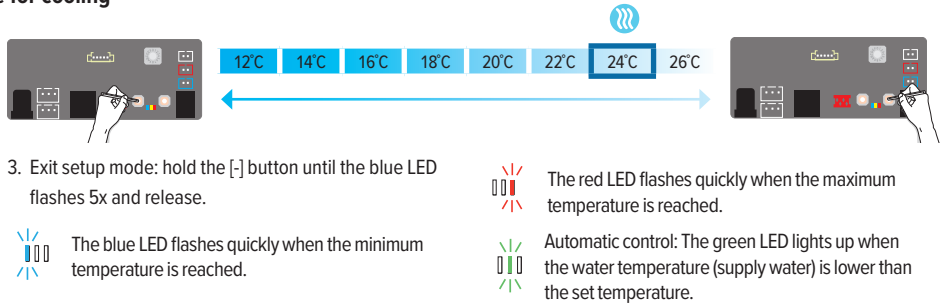

39.1.2. Adjusting the minimum water temperature for heating

By increasing the water temperature setting, the unit will start later. If the water temperature is set lower, the unit will start sooner.

⚠ In combination with a heat pump, it may be necessary to reduce the water temperature.

1. Start setup mode: Press and hold the [+] button until the red LED flashes 5x and release.
2. Short press the [-] or [+] button to adjust the set temperature.

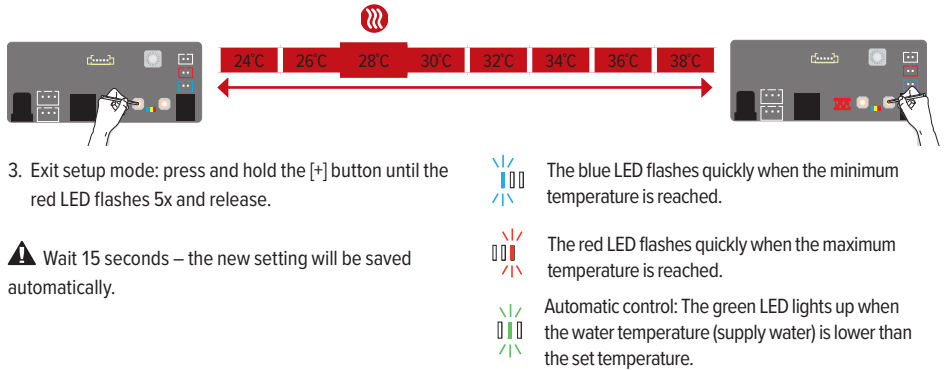

39.2. SETTING FANSPEED

1. Make sure the fan unit is not active (no mode selected).
2. Select a mode to adjust: Press [-] for cooling. Press [+] for heating.
3. Short press [-] or [+] to adjust the preset speed.
4. Wait 15 seconds – the new setting will be saved automatically.

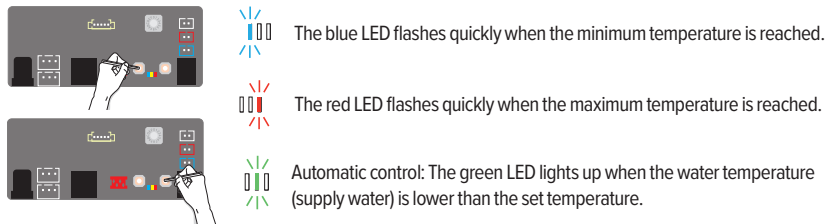

⚠ Note: If the fan unit is already running, the speed of the active mode will be adjusted.

SPEED %																
20	25	30	35	40	45	50	55	60	65	70	75	80	85	90	95	100

39.3. SWITCH ON/OFF WINDOW CONTACT

1. Remember the original setting of the rotary switch
2. Turn the rotary switch to setting '0'
3. The 3 LEDs (red, green and blue) on the JDPC are blinking
4. Hold the '2' button down until the blue or the red LED lights up

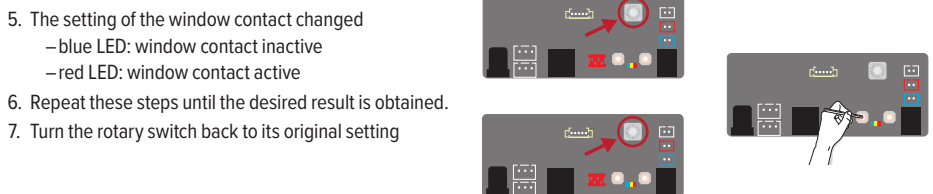

1.2. CIRCUIT BOARD ERROR CODE

39.4. CIRCUIT BOARD ERROR CODE



1.3. FACTORY RESET

39.5. FACTORY RESET

1. Press and hold down both the [-] and [+] button on the circuit board and switch on the power again. The blue LED will light up, followed by the green LED 2 seconds

2. Press and hold down both the [-] and [+] buttons as soon as all 3 LEDs are flashing
3. The controller will return to the Factory Default settings, all LEDs will flash for 8 seconds.

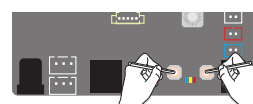

40. WARRANTY CONDITIONS

1. The guarantee is valid only if the equipment is properly and correctly used, by its first owner and if installed in accordance with the norms and instructions as stipulated in the instruction leaflet and the current practices.
2. The guarantee only applies to the equipment and the spare parts. Jaga has the choice between repair and replacement of the equipment or the spare parts. If there has been a change in the model, Jaga is authorised to replace the guaranteed equipment with an equivalent equipment or equivalent spare parts. In those cases where the guarantee claim is received, during the first six months after the start of the guarantee, on all labour and transport costs.
3. The period of guarantee is mentioned in this certificate. A repair or replacement does not change anything to the original period of guarantee.
4. No guarantee is granted on equipment or spare parts lacking information concerning type or series, or on equipment where this information has been removed or altered, or on equipment that has been repaired or modified by persons not authorized by Jaga.
5. The customer is responsible for the damage when it is due to errors of placement, fittings, electrical connections, faulty or damaged electrical installations or appliances, erroneous voltage or hydronic pressure and all other errors not related to the product delivered by Jaga. The guarantee is also revoked when non-suited parts are applied. The guarantee for our heat exchangers is not valid if they are emptied at set times or during a certain period, or if they are heated by means of industrial water, steam or water saturated by great quantities of oxygen. The quality of the system water has to be in accordance with the VDI 2035-2 directive. The buyer will make every effort to prevent damage to the device by avoiding both dust and moisture. This means that the customer has to cover the device in case of further construction works in order to ensure that the devices remain dust-free. The guarantee is also revoked when the heat exchangers are placed in aggressive surroundings (ammonia, corrosive substances, etc). In these circumstances, the buyer should address the cause of the damage. Lacquered radiators should not be used in the following (humid) areas: above a bath with a built-in shower unit, in a shower cubical or next to it, in a swimming pool (chlorine) or in a sauna.
6. Jaga does not give a guarantee on faulty equipment due to incorrect handling and/or use of the equipment, the dropping of the equipment or the transport without the necessary precautions, or for all equipment that is built in, in a way that it cannot be reached normally. The guarantee is valid only if the equipment is properly and correctly used, by its first owner and if installed in accordance with the norms and instructions as stipulated in the instruction leaflet and the current practices.
7. In all cases where the guarantee is granted but where the intervention occurs later than 6 months after the start of the guarantee, and in all other cases, labour and transportation costs are calculated according to scales set by Jaga. Customers can get information on those scales either from our sales administration personnel, or from the maintenance engineer.
8. All interventions not covered by the guarantee have to be paid in cash to the maintenance engineer.
9. The guarantee starts on the date of the invoice. If the invoice is not available, the serial number or the date of production prevails.
10. Only the courts of judicial district Hasselt (Belgium) are authorised to deal with disputes arising from this guarantee. It will apply Belgian law even when sales involved are subjects of EU member states as well as non-EU member countries.



Jaga N.V., Verbindingslaan 16, B-3590 Diepenbeek
Tel.: +32 (0)11 29 41 11, Fax: +32 (0)11 32 35 78
Info@jaga.be, www.jaga.com
27200.24300015 - 2026.02.20 - V.0.04