

jaga

CLIMATE DESIGNERS

DBH SET BMS

BMS MODUS 0...10V

INSTALLATIE- EN GEBRUIKERSHANDLEIDING
VERWARMEN OF NIET-CONDENSEREND KOELEN

BMS MODUS 0...10V

MANUEL D'INSTALLATION ET D'UTILISATION
CHAUFFER OU REFROIDIR SANS CONDENSATION

BMS MODUS 0...10V

INSTALLATIONS- UND GEBRAUCHSANLEITUNG
HEIZEN ODER NICHT-KONDENSIEREND KÜHLEN

BMS MODUS 0...10V

INSTALLATION- AND OPERATIONS MANUAL
HEATING OR NON-CONDENSING COOLING



STICKER

CONTENT

1. PRODUCT DESCRIPTION.....	25
2. INSTALLATION.....	26
2.1. ELECTRICAL CONNECTION.....	27
3. OPERATION.....	28
4. SETTINGS VIA CIRCUIT BOARD CONTROLLER.....	28
4.1. ADJUSTING THE WATER TEMPERATURE.....	28
4.2. IN-/UITSCHAKELLEN RAAMCONTACT.....	29
4.3. FOUTCODES PRINTPLAAT.....	29
4.4. TERUG NAAR FABRIEKINSTELLING.....	29
5. GARANTIE.....	30

DECLARATION OF CONFORMITY

CEO JAGA N.V.
Jan Kriekels



21/05/2018

JAGA N.V. - Verbindingslaan 16 - B 3590, declares under its sole responsibility that the product to which this declaration relates: **DBH**

is in conformity with the following standards or documents provided that these are used in accordance with our instructions: **NBN EN60335-1 BASED ON EN60335 -1:2012+A11:2014+A12:2017+A13:2017 NBN EN60335-2 -80 BASED ON EN60335-2-80:2003 + A1:2004+A2:2009 / NBN EN 60335-2-80 based on EN 60335-2-80:2003 - A1:2004 + A2:2009**

Following the provision of Directives as amended:

- Low Voltage 2014/35/EC
- EMC 2014/30/EC
- Machinery 2006/42/EC
- RoHS 2011/65/EU



Important info



The unit must be installed by a certified installer in accordance with the installation instructions and the local building codes. Please follow this instruction manual and file it somewhere safe!

The unit must always be accessible for maintenance and inspection..

The warranty is void when:

- The installation, maintenance or operation instructions in this manual are not respected.
- The initial start-up has been carried out before a general cleaning of both the fan and the coil.
- Modifications have been made to the product, before, during or after product installation.
- Maintenance has been carried out by unauthorized people.

-Access to the unit has been restricted due to on-site conditions.

This device is covered by the general warranty conditions of Jaga NV.

1. PRODUCT DESCRIPTION



* CONNECTING THE CONTROL UNIT

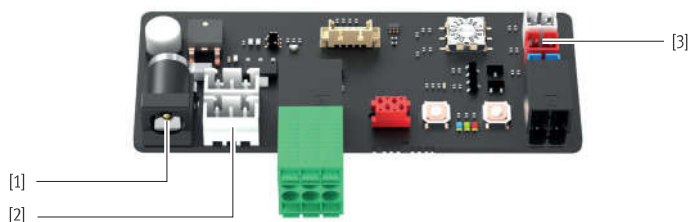

2. INSTALLATION

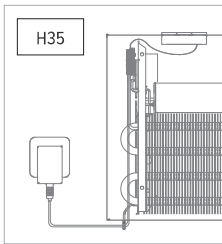
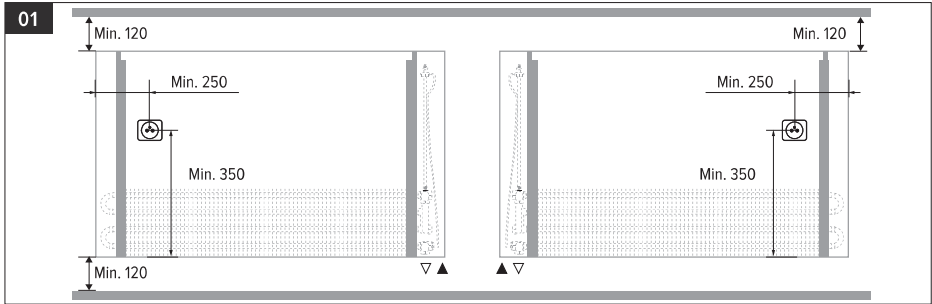

⚠ 230 V is not possible in a casing with a height of 35 cm.

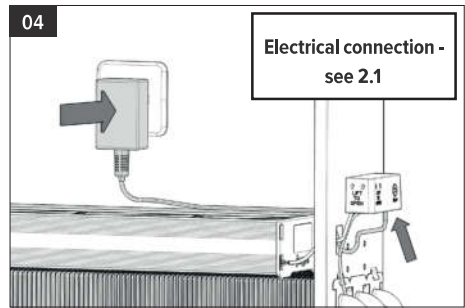
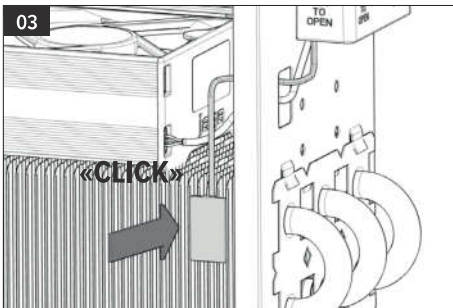
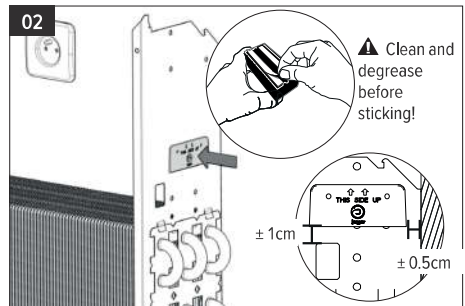

2.1. ELECTRICAL CONNECTION

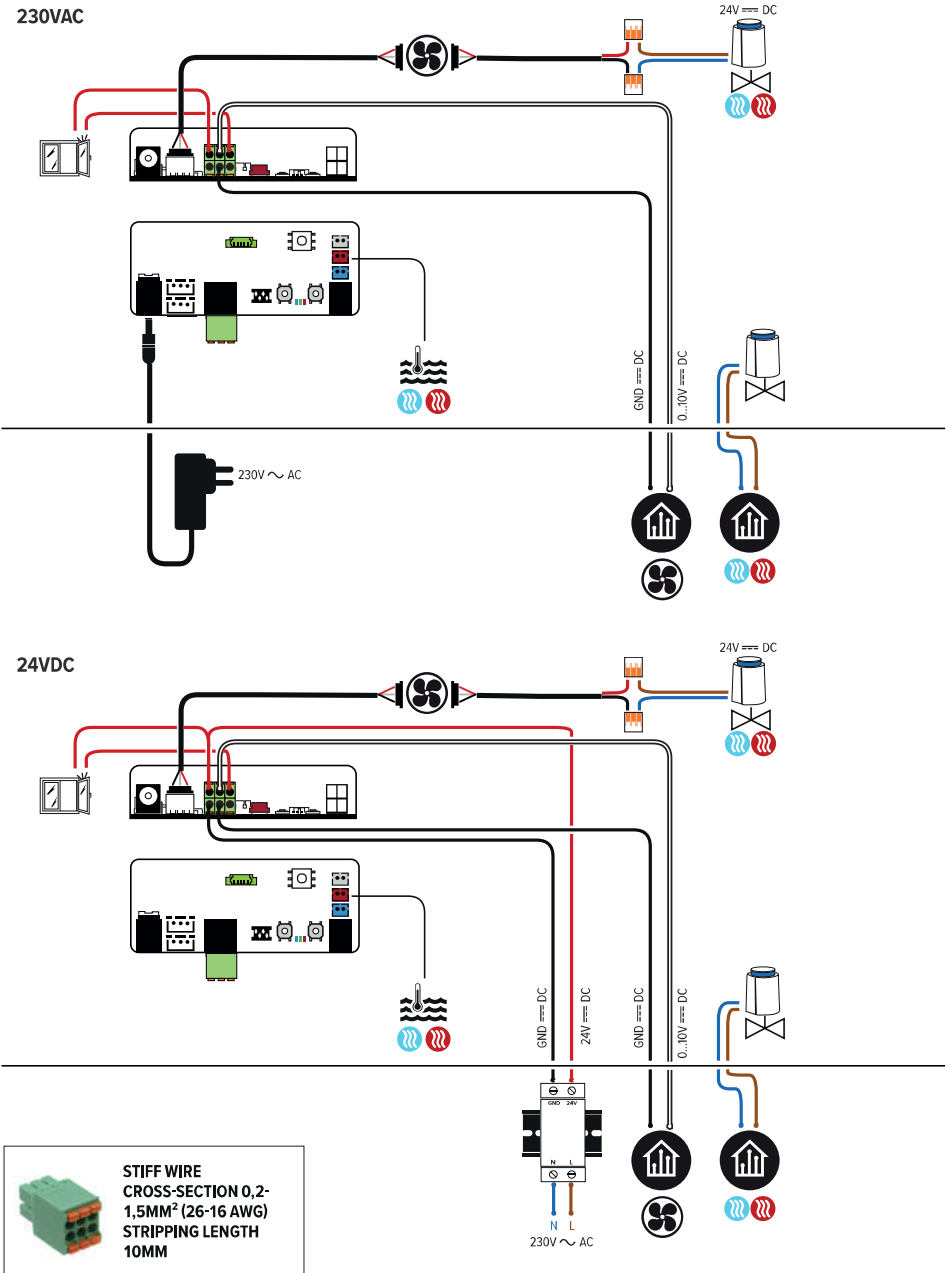

3. OPERATION

When heat or cold is requested, a BMS/home automation system or JAGA thermostat will send a 0-10V signal. When detecting cold or hot water, the fan will rotate proportionally to the 0-10V signal.



The thermoelectric valve will open as soon as the incoming command signal > 1.5V.
The thermoelectric valve closes as soon as the incoming command signal < 0.5V.

Optional:



When heat or cold are requested, the BMS/home automation system will open up the thermoelectric valve.

4. SETTINGS VIA CIRCUIT BOARD CONTROLLER

4.1. ADJUSTING THE WATER TEMPERATURE

4.1.1. Adjusting the maximum water temperature for cooling

By reducing the water temperature setting, the unit will start later. If the water temperature is set higher, the unit will start sooner.

1. Start setup mode: press and hold the [-] button until the blue LED flashes 5x and release.
2. Short press the [-] or [+] button to adjust the set temperature.

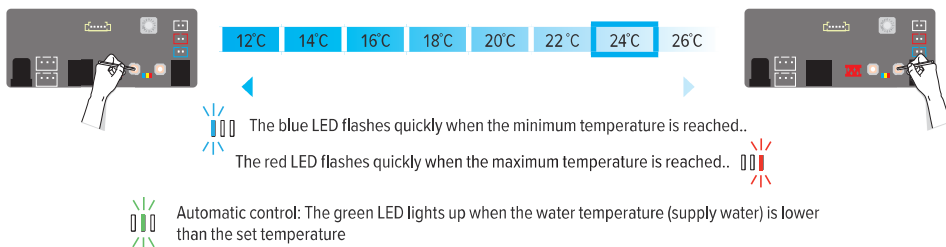

3. Exit setup mode: hold the [-] button until the blue LED flashes 5x and release. After 30 seconds, the new settings are automatically saved and the device returns to the selected mode.

4.1.2. Adjusting the minimum water temperature for heating

By increasing the water temperature setting, the unit will start later. If the water temperature is set lower, the unit will start sooner.

 In combination with a heat pump, it may be necessary to reduce the water temperature.

- 1.Start setup mode: Press and hold the [+] button until the red LED flashes 5x and release.
- 2.Short press the [-] or [+] button to adjust the set temperature.

The blue LED flashes quickly when the minimum temperature is reached..

The red LED flashes quickly when the maximum temperature is reached..

Automatic control: The green LED lights when the water temperature (supply water) exceeds the set temperature.

- 3.Exit setup mode: press and hold the [+] button until the red LED flashes 5x and release. After 30 seconds, the new settings are automatically saved and the device returns to the selected mode.

EN

4.2. SWITCH ON/OFF WINDOW CONTACT

- 1.remember the original setting of the rotary switch
- 2.turn the rotary switch to setting '0'
- 3.the 3 LEDs (red, green and blue) on the JDPC are blinking
- 4.hold the '-' button down until the blue or the red LED lights up
- 5.the setting of the window contact changed
 - blue LED: window contact inactive
 - red LED: window contact active
- 6.repeat these steps until the desired result is obtained.
- 7.turn the rotary switch back to its original setting

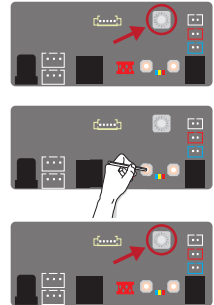

4.3. CIRCUIT BOARD ERROR CODE

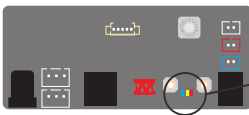

Check the water temperature sensor

4.4. FACTORY RESET

- 1.Disable power charge.
- 2.Press and hold down both the [-] and [+] button on the circuit board and switch on the power again. The blue LED will light up, followed by the green LED 2 seconds later and the red LED 4 seconds later. Release the buttons as soon as all 3 LEDs are flashing
- 3.The controller will return to the Factory Default settings, all LEDs will flash for 8 seconds..



5. GUARANTEE

1. The guarantee is valid only if the equipment is properly and correctly used, by its first owner and if installed in accordance with the norms and instructions as stipulated in the instruction leaflet and the current practices.
2. The guarantee only applies to the equipment and the spare parts. Jaga has the choice between repair and replacement of the equipment or the spare parts. If there has been a change in the model, Jaga is authorised to replace the guaranteed equipment with an equivalent equipment or equivalent spare parts. In those cases where the guarantee claim is received, during the first six months after the start of the guarantee, on all labour and transport costs.
3. The period of guarantee is mentioned in this certificate. A repair or replacement does not change anything to the original period of guarantee.
4. No guarantee is granted on equipment or spare parts lacking information concerning type or series, or on equipment where this information has been removed or altered, or on equipment that has been repaired or modified by persons not authorized by Jaga.
5. The customer is responsible for the damage when it is due to errors of placement, fittings, electrical connections, faulty or damaged electrical installations or appliances, erroneous voltage or hydronic pressure and all other errors not related to the product delivered by Jaga. The guarantee is also revoked when non-suited parts are applied. The guarantee for our heat exchangers is not valid if they are emptied at set times or during a certain period, or if they are heated by means of industrial water, steam or water saturated by great quantities of oxygen. The quality of the system water has to be in accordance with the VDI 2035-2 directive. The buyer will make every effort to prevent damage to the device by avoiding both dust and moisture. This means that the customer has to cover the device in case of further construction works in order to ensure that the devices remain dust-free. The guarantee is also revoked when the heat exchangers are placed in aggressive surroundings (ammonia, corrosive substances, etc). In these circumstances, the buyer should address the cause of the damage. Lacquered radiators should not be used in the following (humid) areas: above a bath with a built-in shower unit, in a shower cubical or next to it, in a swimming pool (chlorine) or in a sauna.
6. Jaga does not give a guarantee on faulty equipment due to incorrect handling and/or use of the equipment, the dropping of the equipment or the transport without the necessary precautions, or for all equipment that is built in, in a way that it cannot be reached normally. The guarantee is valid only if the equipment is properly and correctly used, by its first owner and if installed in accordance with the norms and instructions as stipulated in the instruction leaflet and the current practices.
7. In all cases where the guarantee is granted but where the intervention occurs later than 6 months after the start of the guarantee, and in all other cases, labour and transportation costs are calculated according to scales set by Jaga. Customers can get information on those scales either from our sales administration personnel, or from the maintenance engineer.
8. All interventions not covered by the guarantee have to be paid in cash to the maintenance engineer.
9. The guarantee starts on the date of the invoice. If the invoice is not available, the serial number or the date of production prevails.
10. Only the courts of judicial district Hasselt (Belgium) are authorised to deal with disputes arising from this guarantee. It will apply Belgian law even when sales involved are subjects of EU member states as well as non-EU member countries.

