

jaga
CLIMATE DESIGNERS



IGUANA



IGUANA

CONTENIDO	3	Iguana Corner (Plus)	12
INFORMACIÓN TÉCNICA	4	Dimensiones	12
Iguana Circo	4	Suministro estándar	12
Dimensiones	4	Opción toallero	12
Suministro estándar	4	Tabla técnica	12
Opción toallero	4	Iguana Angula Plus	14
Tabla técnica	4	Dimensiones	14
Iguana Aplano (Plus)	6	Suministro estándar	14
Dimensiones	6	Tabla técnica	14
Suministro estándar	6	Sets de conexión más utilizados	16
Opción toallero	6	Factores de corrección	17
Tabla técnica	6	Directriz para limitar el ruido	17
Iguana Arco (Plus)	8	Pérdidas de carga	18
Dimensiones	8	Iguana Circo	18
Suministro estándar	8	Iguana Aplano (Plus)	19
Opción toallero	8	Iguana Arco (Plus)	20
Tabla técnica	8	Iguana Visio (Plus)	21
Iguana Visio (Plus)	10	Iguana Corner (Plus)	22
Dimensiones	10	Iguana Angula Plus	23
Suministro estándar	10		
Opción toallero	10		
Tabla técnica	10		



Top 10
Design
Award
2009

DESIGN PLUS

IGUANA CIRCO

DIMENSIONES (en mm)

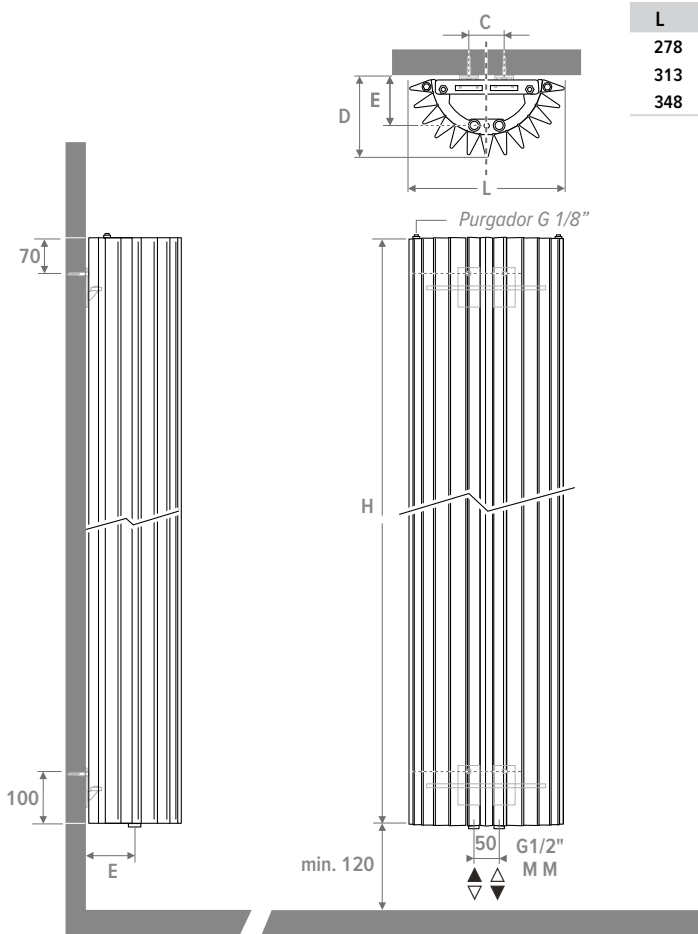

L	C	D	E
278	74	142	77
313	108	157	96
348	144	177	115

CÓDIGO PEDIDO

CIRW 180 027 XXX MM

Color
Longitud
Altura

SUMINISTRO ESTÁNDAR

- conexión central inferior MM
- set de fijación a pared
- 2 purgadores cromados G 1/8"

COLORES

Respetuoso con el medio ambiente, lacado con polvo resistente al rayado y con alta resistencia a los UV

Colores estándar

- blanco tráfico RAL 9016 (333) satinado mate
- gris metálico arena (001), lacado con fina textura metálica
- off-black (145). "Soft touch" lacado mate ligeramente estructurado

Otros colores

Ver carta de colores Jaga. Sobrecoste: +20%

TOALLERO

en aluminio cromado

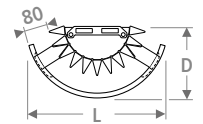

CÓDIGO	L Emisor	L	D
9087 013427	ø 27	43	22
9087 013427	ø 31	43	22
9087 013493	ø 34	49	25

IGUANA CIRCO

TABLA TÉCNICA

ALTURA H	LONGITUD L	CALEFACCIÓN Temperatura ambiente 20°C			PESO kg	CONTENIDO DE AGUA L	CÓDIGO PEDIDO
		45/40 Wattios	55/45 Wattios	75/65 Wattios			
CIRW 180	027	254	381	801	31	28.7	CIRW 180 027 XXX MM
	031	300	450	946	37	33.8	CIRW 180 031 XXX MM
	034	347	520	1092	42	39.0	CIRW 180 034 XXX MM
192	027	275	410	854	33	30.4	CIRW 192 027 XXX MM
	031	325	485	1009	39	35.9	CIRW 192 031 XXX MM
	034	375	559	1164	44	41.4	CIRW 192 034 XXX MM
200	027	288	429	887	34	31.6	CIRW 200 027 XXX MM
	031	341	507	1048	40	37.3	CIRW 200 031 XXX MM
	034	393	585	1209	46	43.0	CIRW 200 034 XXX MM
220	027	320	472	961	37	34.5	CIRW 220 027 XXX MM
	031	379	558	1136	44	40.8	CIRW 220 031 XXX MM
	034	437	644	1311	50	47.0	CIRW 220 034 XXX MM
240	027	349	511	1024	41	37.7	CIRW 240 027 XXX MM
	031	413	604	1210	48	44.4	CIRW 240 031 XXX MM
	034	477	697	1397	55	51.3	CIRW 240 034 XXX MM

Emisión EN442 a 20°C

introduce el código de color



Top 10
Design
Award
Winner
2000

1999
DESIGN PLUS
Award Winner 2000

IGUANA APLANO (PLUS)

DIMENSIONES (en mm)

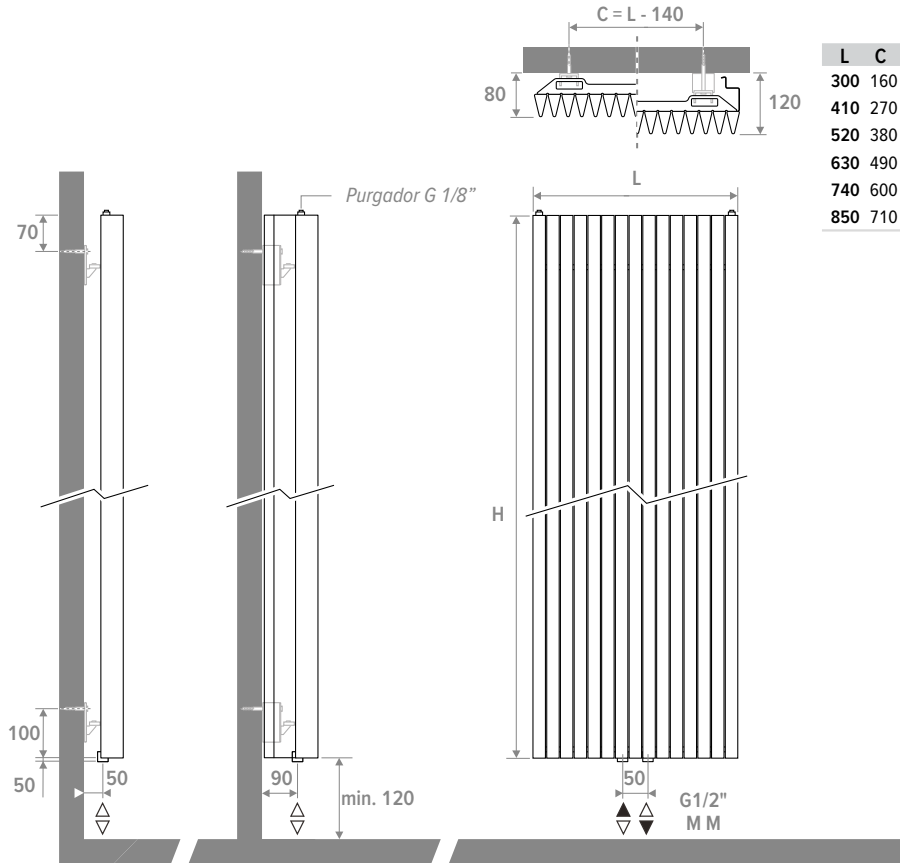

L	C
300	160
410	270
520	380
630	490
740	600
850	710

CÓDIGO PEDIDO



SUMINISTRO ESTÁNDAR

- conexión central inferior MM
- set de fijación a pared
- 2 purgadores cromados G 1/8"
- Iguana Plus está equipado con 2 paneles laterales

COLORES

Respetuoso con el medio ambiente, lacado con polvo resistente al rayado y con alta resistencia a los UV

Colores estándar

- blanco tráfico RAL 9016 (333) satinado mate
- gris metálico arena (001), lacado con fina textura metálica
- off-black (145). "Soft touch" lacado mate ligeramente estructurado

Otros colores

Ver carta de colores Jaga. Sobrecoste: +20%

TOALLERO

en aluminio cromado



CÓDIGO	L Emisor	L
9087 033560	41-52-63-74-85	56
9087 033660	63-74-85	66

IGUANA APLANO

TABLA TÉCNICA

ALTURA H	LONGITUD L	CALEFACCIÓN Temperatura ambiente 20°C			PESO		CONTENIDO DE AGUA L	CÓDIGO PEDIDO
		45/40 Wattios	55/45 Wattios	75/65 Wattios	kg	L		
180	030	239	349	700	31	9.6		APLW 180 030 XXX MM
	041	326	476	954	41	13.1		APLW 180 041 XXX MM
	052	412	603	1208	52	16.6		APLW 180 052 XXX MM
	063	499	730	1463	63	20.0		APLW 180 063 XXX MM
	074	586	857	1717	73	23.5		APLW 180 074 XXX MM
	085	673	984	1972	84	27.0		APLW 180 085 XXX MM
192	030	251	366	733	33	10.2		APLW 192 030 XXX MM
	041	342	499	999	44	13.9		APLW 192 041 XXX MM
	052	433	632	1265	55	17.7		APLW 192 052 XXX MM
	063	524	766	1532	66	21.4		APLW 192 063 XXX MM
	074	615	899	1798	78	25.1		APLW 192 074 XXX MM
	085	706	1032	2065	89	28.8		APLW 192 085 XXX MM
200	030	259	377	754	34	10.6		APLW 200 027 XXX MM
	041	353	515	1028	45	14.5		APLW 200 031 XXX MM
	052	446	652	1302	57	18.4		APLW 200 031 XXX MM
	063	540	789	1576	69	22.3		APLW 200 031 XXX MM
	074	634	926	1850	80	26.1		APLW 200 031 XXX MM
	085	728	1063	2124	92	30.0		APLW 200 034 XXX MM
220	030	277	403	804	37	11.7		APLW 220 030 XXX MM
	041	378	551	1097	50	16.0		APLW 220 041 XXX MM
	052	478	697	1389	62	20.2		APLW 220 052 XXX MM
	063	579	844	1681	75	24.5		APLW 220 063 XXX MM
	074	680	991	1974	88	28.8		APLW 220 074 XXX MM
	085	780	1137	2266	101	33.0		APLW 220 085 XXX MM
240	030	294	428	851	40	12.8		APLW 240 030 XXX MM
	041	402	584	1161	54	17.4		APLW 240 041 XXX MM
	052	509	740	1471	68	22.1		APLW 240 052 XXX MM
	063	616	896	1780	82	26.7		APLW 240 063 XXX MM
	074	723	1052	2090	96	31.4		APLW 240 074 XXX MM
	085	830	1208	2399	110	36.0		APLW 240 085 XXX MM

Emisión EN442 a 20°C

introduce el código de color

IGUANA APLANO PLUS

TABLA TÉCNICA

ALTURA H	LONGITUD L	CALEFACCIÓN Temperatura ambiente 20°C			PESO		CONTENIDO DE AGUA L	CÓDIGO PEDIDO
		45/40 Wattios	55/45 Wattios	75/65 Wattios	kg	L		
180	030	308	461	964	9.6			APPW 180 030 XXX MM
	041	420	628	1314	13.1			APPW 180 041 XXX MM
	052	531	795	1664	16.6			APPW 180 052 XXX MM
	063	644	963	2015	20.0			APPW 180 063 XXX MM
	074	755	1131	2365	23.5			APPW 180 074 XXX MM
	085	867	1298	2716	27.0			APPW 180 085 XXX MM
192	030	318	476	997	10.2			APPW 192 030 XXX MM
	041	434	649	1359	13.9			APPW 192 041 XXX MM
	052	549	822	1721	17.7			APPW 192 052 XXX MM
	063	665	996	2084	21.4			APPW 192 063 XXX MM
	074	781	1169	2446	25.1			APPW 192 074 XXX MM
	085	896	1342	2809	28.8			APPW 192 085 XXX MM
200	030	679	1017	2128	10.6			APPW 200 030 XXX MM
	041	797	1194	2498	14.5			APPW 200 041 XXX MM
	052	915	1370	2868	18.4			APPW 200 052 XXX MM
	063	325	486	1018	22.3			APPW 200 063 XXX MM
	074	443	663	1388	26.1			APPW 200 074 XXX MM
	085	561	840	1758	30.0			APPW 200 085 XXX MM
220	030	341	511	1070	11.7			APPW 220 030 XXX MM
	041	466	697	1460	16.0			APPW 220 041 XXX MM
	052	590	883	1849	20.2			APPW 220 052 XXX MM
	063	714	1069	2238	24.5			APPW 220 063 XXX MM
	074	838	1255	2627	28.8			APPW 220 074 XXX MM
	085	962	1440	3016	33.0			APPW 220 085 XXX MM
240	030	357	535	1121	12.8			APPW 240 030 XXX MM
	041	487	729	1529	17.4			APPW 240 041 XXX MM
	052	616	924	1936	22.1			APPW 240 052 XXX MM
	063	746	1118	2344	26.7			APPW 240 063 XXX MM
	074	876	1312	2751	31.4			APPW 240 074 XXX MM
	085	1006	1507	3159	36.0			APPW 240 085 XXX MM

Emisión EN442 a 20°C

introduce el código de color



Top 10
Design
Award
Winners
2016

DESIGN PLUS

IGUANA ARCO (PLUS)

DIMENSIONES (en mm)

L	C	D1	D2	E1	E2
298	100	101	141	41	81
410	200	111	161	51	101
519	300	127	177	67	117
625	400	122	172	62	112
733	500	137	187	77	127
839	600	157	207	97	147

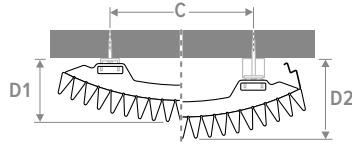

CÓDIGO PEDIDO

ARCW 180 029 XXX MM

Color

Longitud

Altura

Iguana Arco: ARCW

Iguana Arco Plus: ARPW

SUMINISTRO ESTÁNDAR

- conexión central inferior MM
- set de fijación a pared
- 2 purgadores cromados G 1/8"
- Iguana Plus está equipado con 2 paneles laterales

COLORES

Respetuoso con el medio ambiente, lacado con polvo resistente al rayado y con alta resistencia a los UV

Colores estándar

- blanco tráfico RAL 9016 (333) satinado mate
- gris metálico arena (001), lacado con fina textura metálica
- off-black (145). "Soft touch" lacado mate ligeramente estructurado

Otros colores

ver carta de colores Jaga. Sobrecoste: +20%

TOALLERO

en aluminio cromado

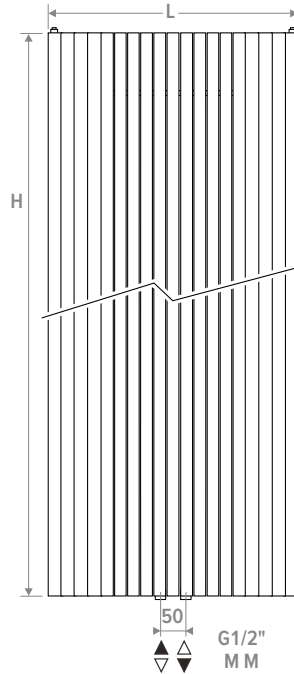
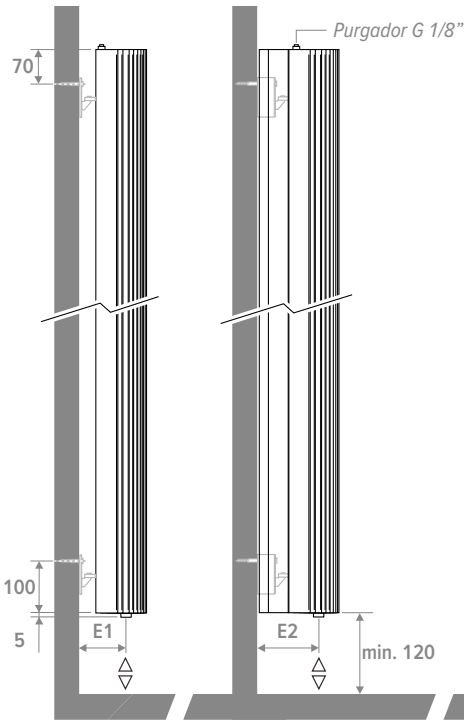
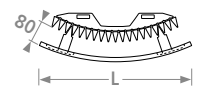
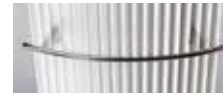

CÓDIGO	L Emisor	L
9087 023550	41 - 51	55
9087 023656	62 - 73 - 83	66

IGUANA ARCO

TABLA TÉCNICA

ALTURA	LONGITUD	CALEFACCIÓN Temperatura ambiente 20°C			PESO	CONTENIDO DE AGUA	CÓDIGO PEDIDO
		45/40	55/45	75/65			
H	L	Wattios	Wattios	Wattios	kg	L	
cm	cm						
ARCW 180	029	269	394	791	31	9.6	ARCW 180 029 XXX MM
	041	367	538	1079	42	13.1	ARCW 180 041 XXX MM
	051	465	681	1366	53	16.6	ARCW 180 051 XXX MM
	062	563	824	1654	64	20.0	ARCW 180 062 XXX MM
	073	661	967	1941	74	23.5	ARCW 180 073 XXX MM
083	759	1111	2229	85	27.0	ARCW 180 083 XXX MM	
192	029	278	406	813	33	10.2	ARCW 192 029 XXX MM
	041	379	554	1109	44	13.9	ARCW 192 041 XXX MM
	051	480	701	1404	56	17.7	ARCW 192 051 XXX MM
	062	581	849	1700	67	21.4	ARCW 192 062 XXX MM
	073	681	996	1995	79	25.1	ARCW 192 073 XXX MM
083	782	1144	2291	90	28.8	ARCW 192 083 XXX MM	
200	029	283	413	826	34	10.6	ARCW 200 029 XXX MM
	041	386	564	1127	46	14.5	ARCW 200 041 XXX MM
	051	489	714	1427	58	18.4	ARCW 200 051 XXX MM
	062	591	864	1727	70	22.3	ARCW 200 062 XXX MM
	073	694	1014	2028	82	26.1	ARCW 200 073 XXX MM
083	797	1164	2328	94	30.0	ARCW 200 083 XXX MM	
220	029	295	431	858	37	11.7	ARCW 220 029 XXX MM
	041	403	587	1170	50	16.0	ARCW 220 041 XXX MM
	051	510	744	1482	63	20.2	ARCW 220 051 XXX MM
	062	618	900	1794	76	24.5	ARCW 220 062 XXX MM
	073	725	1057	2106	89	28.8	ARCW 220 073 XXX MM
083	832	1213	2418	102	33.0	ARCW 220 083 XXX MM	
240	029	307	446	886	41	12.8	ARCW 240 029 XXX MM
	041	418	608	1208	55	17.4	ARCW 240 041 XXX MM
	051	529	770	1530	69	22.1	ARCW 240 051 XXX MM
	062	641	932	1852	83	26.7	ARCW 240 062 XXX MM
	073	752	1094	2174	97	31.4	ARCW 240 073 XXX MM
083	863	1256	2496	111	36.0	ARCW 240 083 XXX MM	

introduce el código de color

IGUANA ARCO PLUS

TABLA TÉCNICA

ALTURA	LONGITUD	CALEFACCIÓN Temperatura ambiente 20°C			PESO	CONTENIDO DE AGUA	CÓDIGO PEDIDO
		45/40	55/45	75/65			
H	L	Wattios	Wattios	Wattios	kg	L	
cm	cm						
ARPW 180	029	334	492	999	9.6		ARPW 180 029 XXX MM
	041	455	670	1362	13.1		ARPW 180 041 XXX MM
	051	576	849	1725	16.6		ARPW 180 051 XXX MM
	062	697	1027	2088	20.0		ARPW 180 062 XXX MM
	073	819	1207	2452	23.5		ARPW 180 073 XXX MM
083	940	1385	2815	27.0		ARPW 180 083 XXX MM	
192	029	351	516	1046	10.2		ARPW 192 029 XXX MM
	041	479	704	1427	13.9		ARPW 192 041 XXX MM
	051	606	892	1807	17.7		ARPW 192 051 XXX MM
	062	734	1080	2187	21.4		ARPW 192 062 XXX MM
	073	862	1268	2568	25.1		ARPW 192 073 XXX MM
083	989	1455	2948	28.8		ARPW 192 083 XXX MM	
200	029	362	532	1076	10.6		ARPW 200 029 XXX MM
	041	494	726	1467	14.5		ARPW 200 041 XXX MM
	051	626	919	1858	18.4		ARPW 200 051 XXX MM
	062	757	1112	2249	22.3		ARPW 200 062 XXX MM
	073	889	1306	2641	26.1		ARPW 200 073 XXX MM
083	1021	1500	3032	30.0		ARPW 200 083 XXX MM	
220	029	389	569	1146	11.7		ARPW 220 029 XXX MM
	041	530	777	1563	16.0		ARPW 220 041 XXX MM
	051	671	984	1980	20.2		ARPW 220 051 XXX MM
	062	813	1191	2397	24.5		ARPW 220 062 XXX MM
	073	954	1398	2813	28.8		ARPW 220 073 XXX MM
083	1095	1605	3230	33.0		ARPW 220 083 XXX MM	
240	029	413	604	1210	12.8		ARPW 240 029 XXX MM
	041	564	824	1650	17.4		ARPW 240 041 XXX MM
	051	714	1043	2090	22.1		ARPW 240 051 XXX MM
	062	864	1263	2530	26.7		ARPW 240 062 XXX MM
	073	1014	1483	2970	31.4		ARPW 240 073 XXX MM
083	1165	1702	3410	36.0		ARPW 240 083 XXX MM	

introduce el código de color



Top 10
Design
Award
Winner
2000

DESIGN PLUS
SINCE 1999

IGUANA VISIO (PLUS)

DIMENSIONES (en mm)

L	C	D1	D2	E1	E2
278	30	105	155	67	117
313	40	110	160	62	112
348	50	125	175	77	127

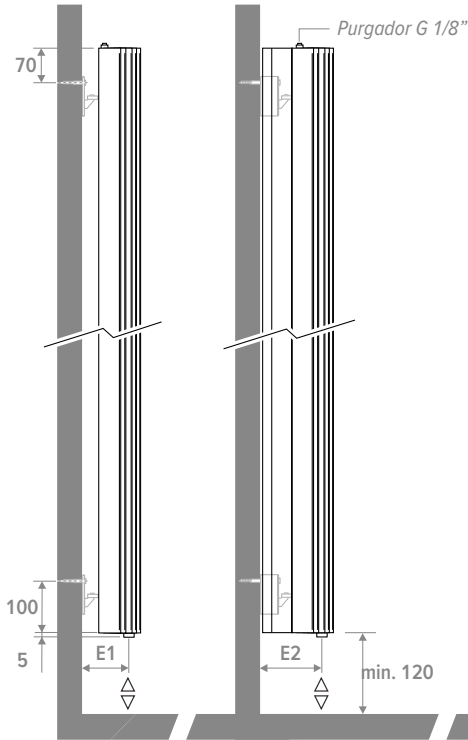
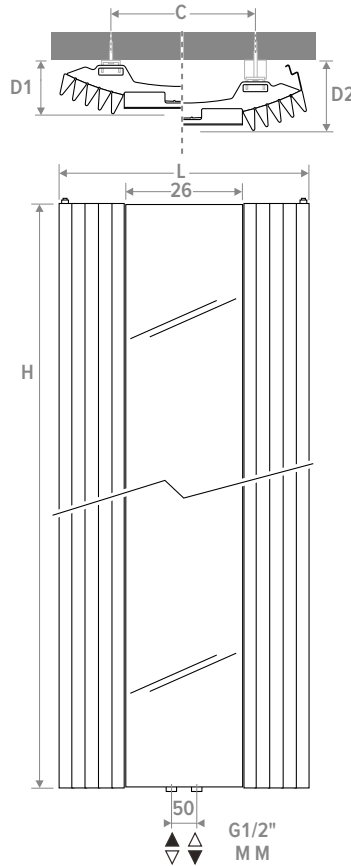

CÓDIGO PEDIDO

VISW 180 029 XXX MM

Color
Longitud
Altura
Iguana Visio: VISW
Iguana Visio Plus: VIPW

SUMINISTRO ESTÁNDAR

- conexión central inferior MM
- set de fijación a pared
- 2 purgadores cromados G 1/8"
- Iguana Plus está equipado con 2 paneles laterales

COLORES

Respetuoso con el medio ambiente, lacado con polvo resistente al rayado y con alta resistencia a los UV

Colores estándar

- blanco tráfico RAL 9016 (333) satinado mate
- gris metálico arena (001), lacado con fina textura metálica
- off-black (145). "Soft touch" lacado mate ligeramente estructurado

Otros colores

Ver carta de colores Jaga. Sobrecoste: +20%

TOALLERO

en aluminio cromado

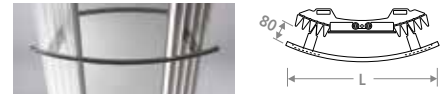

CÓDIGO	L Emisor	L
9087 023550	41 - 51	55
9087 023656	62 - 73 - 83	66

IGUANA VISIO

TABLA TÉCNICA

IGUANA VISIO PLUS

TABLA TÉCNICA

ALTURA	LONGITUD	CALEFACCIÓN Temperatura ambiente 20°C			PESO	CONTENIDO DE AGUA	CÓDIGO PEDIDO
		45/40 Wattios	55/45 Wattios	75/65 Wattios			
H	L						
cm	cm			kg	L		
VISW 180	051	245	358	719	37	10.2	VISW 180 051 XXX MM
	062	343	502	1007	47	12.0	VISW 180 062 XXX MM
	073	441	645	1294	58	13.9	VISW 180 073 XXX MM
200	051	257	376	751	43	11.2	VISW 200 051 XXX MM
	062	360	526	1051	55	13.3	VISW 200 062 XXX MM
	073	463	676	1352	69	15.4	VISW 200 073 XXX MM
220	051	269	391	780	46	12.3	VISW 220 051 XXX MM
	062	376	548	1092	60	14.6	VISW 220 062 XXX MM
	073	483	705	1404	74	16.8	VISW 220 073 XXX MM

introduce el código de color

ALTURA	LONGITUD	CALEFACCIÓN Temperatura ambiente 20°C			PESO	CONTENIDO DE AGUA	CÓDIGO PEDIDO
		45/40 Wattios	55/45 Wattios	75/65 Wattios			
H	L						
cm	cm			kg	L		
VIPW 180	051	303	447	908	10.2		VIPW 180 051 XXX MM
	062	425	625	1271	12.0		VIPW 180 062 XXX MM
	073	546	804	1634	13.9		VIPW 180 073 XXX MM
200	051	329	484	978	11.2		VIPW 200 051 XXX MM
	062	461	677	1369	13.3		VIPW 200 062 XXX MM
	073	593	871	1760	15.4		VIPW 200 073 XXX MM
220	051	353	518	1042	12.3		VIPW 220 051 XXX MM
	062	495	725	1459	14.6		VIPW 220 062 XXX MM
	073	636	932	1876	16.8		VIPW 220 073 XXX MM

introduce el código de color



Top 10
Design
Award
Winner
2000

DESIGN PLUS
Award Trophy Paris

IGUANA CORNER (PLUS)

DIMENSIONES (en mm)

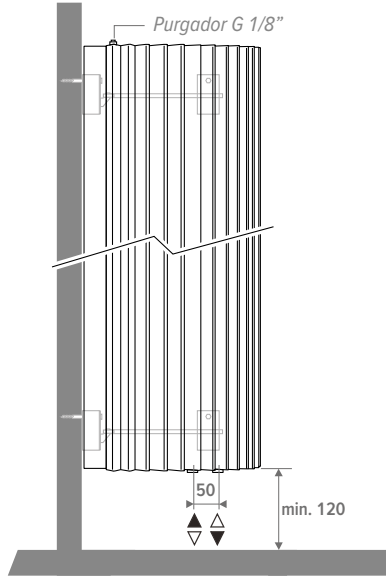
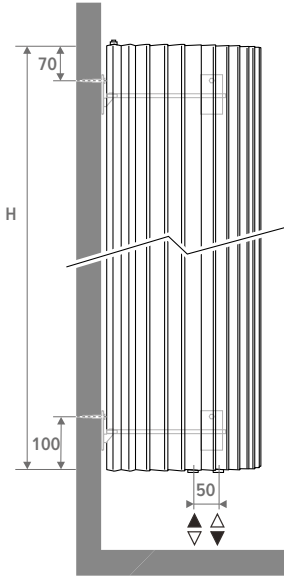
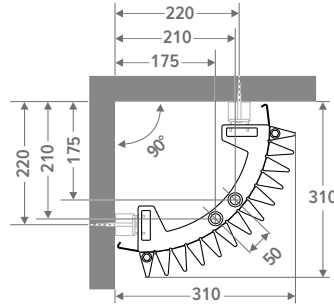
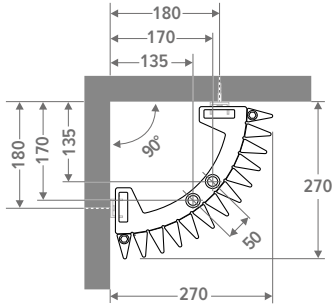

CÓDIGO PEDIDO

CORW 180 029 XXX MM

Color

Longitud

Altura

Iguana Corner: CORW

Iguana Corner Plus: COPW

SUMINISTRO ESTÁNDAR

- conexión central inferior MM
- set de fijación a pared
- 2 purgadores cromados G 1/8"
- Iguana Plus está equipado con 2 paneles laterales

COLORES

Respetuoso con el medio ambiente, lacado con polvo resistente al rayado y con alta resistencia a los UV

Colores estándar

- blanco tráfico RAL 9016 (333) satinado mate
- gris metálico arena (001), lacado con fina textura metálica
- off-black (145). "Soft touch" lacado mate ligeramente estructurado

Otros colores

Ver carta de colores JagA. Sobrecoste: +20%

TOALLERO

en aluminio cromado

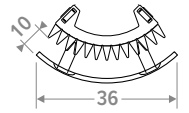

CÓDIGO

9087 043466

IGUANA CORNER

TABLA TÉCNICA

IGUANA CORNER PLUS

TABLA TÉCNICA

ALTURA	LONGITUD	CALEFACCIÓN			PESO	CONTENIDO DE AGUA	CÓDIGO PEDIDO	ALTURA	LONGITUD	CALEFACCIÓN			PESO	CONTENIDO DE AGUA	CÓDIGO PEDIDO
		Temperatura ambiente 20°C								Temperatura ambiente 20°C					
H	L	45/40	55/45	75/65	kg	L		H	L	45/40	55/45	75/65	kg	L	
cm	cm	Wattios	Wattios	Wattios				cm	cm	Wattios	Wattios	Wattios			
CORW 125	027	216	331	723	25	8.6	CORW 125 027 XXX MM	COPW 125	031	297	433	860	8.6		COPW 125 031 XXX MM
150		248	381	834	29	10.2	CORW 150 027 XXX MM	150		341	497	990	10.2		COPW 150 031 XXX MM
180		285	439	967	34	12.0	CORW 180 027 XXX MM	180		391	572	1145	12.0		COPW 180 031 XXX MM
192		300	463	1021	36	12.8	CORW 192 027 XXX MM	192		412	602	1207	12.8		COPW 192 031 XXX MM
200		311	479	1058	38	13.3	CORW 200 027 XXX MM	200		425	622	1249	13.3		COPW 200 031 XXX MM
220		336	519	1149	41	14.6	CORW 220 027 XXX MM	220		458	672	1352	14.6		COPW 220 031 XXX MM
240		361	559	1242	45	15.8	CORW 240 027 XXX MM	240		492	723	1458	15.8		COPW 240 031 XXX MM

introduce el código de color

introduce el código de color



Top 10
Design
Award
Winner
2000

ISSN 1999
DESIGN PLUS
Award Winning Design

IGUANA ANGULA PLUS

DIMENSIONES (en mm)

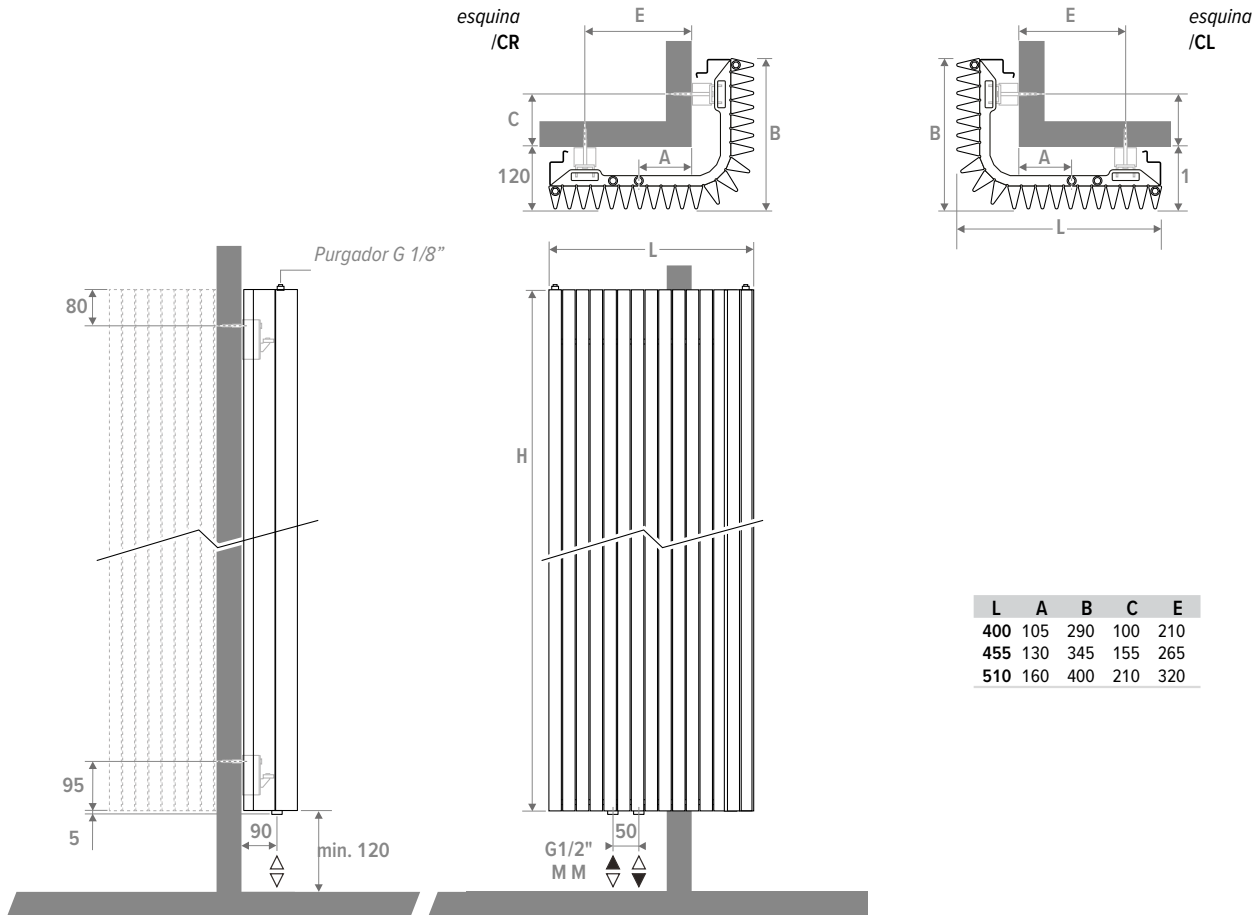

L	A	B	C	E
400	105	290	100	210
455	130	345	155	265
510	160	400	210	320

CÓDIGO PEDIDO

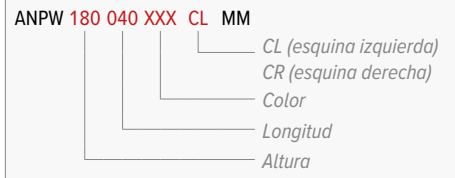

SUMINISTRO ESTÁNDAR

- conexión central inferior MM
- set de fijación a pared
- 2 purgadores cromados G 1/8"
- 2 barras laterales

COLORES

Respetuoso con el medio ambiente, lacado con polvo resistente al rayado y con alta resistencia a los UV

Colores estándar

- blanco tráfico RAL 9016 (333) satinado mate
- gris metálico arena (001), lacado con fina textura metálica
- off-black (145). "Soft touch" lacado mate ligeramente estructurado

Otros colores

ver carta de colores Jaga. Sobrecoste: +20%

IGUANA ANGULA PLUS

ALTURA H cm	LONGITUD L cm	CALEFACCIÓN Temperatura ambiente 20°C			PESO CONTENIDO DE AGUA kg L	CÓDIGO PEDIDO
		45/40 Wattios	55/45 Wattios	75/65 Wattios		
ANPW 180	040	591	866	1745	19.4	ANPW 180 040 XXX CL MM
	046	704	1032	2078	21.8	ANPW 180 046 XXX CL MM
	051	816	1196	2410	24.9	ANPW 180 051 XXX CL MM
192	040	623	911	1823	20.7	ANPW 192 040 XXX CL MM
	046	742	1084	2170	23.3	ANPW 192 046 XXX CL MM
	051	860	1257	2517	26.7	ANPW 192 051 XXX CL MM
200	040	644	938	1871	20.7	ANPW 200 040 XXX CL MM
	046	766	1118	2228	24.3	ANPW 200 046 XXX CL MM
	051	889	1296	2584	27.8	ANPW 200 051 XXX CL MM
220	040	691	1002	1978	22.7	ANPW 220 040 XXX CL MM
	046	823	1193	2355	26.6	ANPW 220 046 XXX CL MM
	051	955	1385	2732	30.5	ANPW 220 051 XXX CL MM
240	040	734	1058	2066	24.8	ANPW 240 040 XXX CL MM
	046	874	1260	2460	29.1	ANPW 240 046 XXX CL MM
	051	1014	1461	2854	33.4	ANPW 240 051 XXX CL MM

introduce el código de color
esquina izquierda / esquina derecha

A pared - DECO PRO VÁLVULA

Set completo cromado

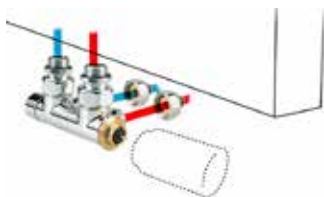

set **41** KVS: 1.65 / 2.20
BITUBO / MONOTUBO

CODE PW3 AC 1...	AC	
CODE PW3 AW 1...	AW	
CODE PW3 AS 1...	AS	
CODE PW3 AB 1...	AB	

completar con el código del racor

Set completo en efecto acero inoxidable bruñido (SS)



set **48** KVS: 1.65 / 2.20
BITUBO / MONOTUBO

CODE PW3 PS 1...	PS	
------------------	----	--

completar con el código del racor

Set completo en efecto aluminio anodizado (ALU)



set **48** KVS: 1.65 / 2.20
BITUBO / MONOTUBO

CODE PW3 PA 1...	PA	
------------------	----	--

completar con el código del racor

A suelo - DECO PRO VÁLVULA

Set completo cromado



set **42** KVS: 1.65 / 2.20
BITUBO / MONOTUBO

CODE PF3 AC 1...	AC	
CODE PF3 AW 1...	AW	
CODE PF3 AS 1...	AS	
CODE PF3 AB 1...	AB	

completar con el código del racor

Set completo en efecto acero inoxidable bruñido (SS)



set **48** KVS: 1.65 / 2.20
BITUBO / MONOTUBO

CODE PF3 PS 1...	PS	
------------------	----	--

completar con el código del racor

Set completo en efecto aluminio anodizado (ALU)



set **49** KVS: 1.65 / 2.20
BITUBO / MONOTUBO

CODE PF3 PA 1...	PA	
------------------	----	--

completar con el código del racor

Racores M24

TUBO DE COBRE / ACERO FINO		SINTÉTICO	
CÓDIGO	Tuberías Ø	CÓDIGO	Tuberías Ø
110	10/1	212	12/2
112	12/1	219	16/1.5
114	14/1	216	16/2
115	15/1	217	17/2
118	18/1	218	18/2

PER/ALU		TUBERÍA DE ACERO	
CÓDIGO	Tuberías Ø	CÓDIGO	Tuberías Ø
314	14/2	501	M24 x 1/2"
316	16/2	503	M24 x 3/8"
326	16/2.2		
318	18/2		

Información detallada de las válvulas, ver el catálogo "Sets de conexión y válvulas".

Las emisiones indicadas con ΔT 50 (75/65/20) son valores exactos medidos según la EN442. Para el resto de ΔT , esta tabla indica un valor calculado utilizando un factor de corrección medio válido para todas las dimensiones.

En www.jaga.info/descargas/selection_tools/ se pueden descargar herramientas de cálculo con las emisiones exactas. Las herramientas de cálculo online se mantienen siempre actualizadas con los datos más recientes. Por lo tanto, las pequeñas diferencias entre las tablas impresas y las diversas herramientas de cálculo online son completamente normales y se encuentran dentro de los márgenes de tolerancia establecidos por la norma.

FACTORES DE CORRECCIÓN MEDIOS PARA PRODUCTOS ESTÁTICOS SEGÚN EN442 - 75/65/20°C

temperatura ambiente: 20°C Valor-N medio: 1.36

	TR	65	60	55	50	45	40	35	30	25
TA										
75	1.00	0.93	0.85	0.77	0.69	0.61	0.52	0.42	0.31	
70	0.94	0.87	0.79	0.72	0.64	0.56	0.48	0.39	0.28	
65		0.80	0.74	0.67	0.60	0.52	0.44	0.35	0.25	
60			0.68	0.61	0.55	0.48	0.40	0.32	0.23	
55				0.56	0.50	0.43	0.36	0.29	0.20	
50					0.44	0.38	0.32	0.25	0.18	
45						0.34	0.28	0.22	0.15	
40							0.24	0.19	0.13	
35								0.15	0.10	
30									0.07	

temperatura ambiente: 24°C Valor-N medio: 1.36

	TR	65	60	55	50	45	40	35	30	25
TA										
75		0.89	0.82	0.75	0.67	0.59	0.51	0.41	0.31	0.16
70		0.83	0.76	0.69	0.62	0.54	0.47	0.38	0.28	0.14
65			0.70	0.64	0.57	0.50	0.43	0.35	0.25	0.12
60				0.58	0.52	0.45	0.38	0.31	0.23	0.11
55					0.47	0.41	0.34	0.28	0.20	0.09
50						0.36	0.30	0.24	0.17	0.08
45							0.26	0.20	0.14	0.06
40								0.17	0.12	0.05
35									0.09	0.03
30										0.02

DIRECTRIZ PARA LIMITAR EL RUIDO

TUBERÍAS	Ø exterior mm	Grosor de la pared mm	Velocidad máxima del agua (EN10255) m/s	contenido de agua por metro l	caudal máx. de agua kg/h	Potencia máxima a ΔT (°C) (T impulsión - T retorno)								
						ΔT 30	ΔT 20	ΔT 10	ΔT 5	ΔT 4	ΔT 3	ΔT 2		
						Wattios	Wattios	Wattios	Wattios	Wattios	Wattios	Wattios		
TUBO GALVANIZADO DIN 2440														
3/8 DN10 OD	17.2	2.35	0.40	0.12	173	6028	4019	2009	1005	804	603	402		
1/2 DN15 OD	21.3	2.65	0.40	0.20	288	10046	6698	3349	1674	1340	1005	670		
3/4 DN20 OD	26.9	2.65	0.42	0.37	559	19515	13010	6505	3253	2602	1952	1301		
1 DN25 OD	33.7	3.25	0.49	0.58	1023	35690	23793	11897	5948	4759	3569	2379		
1 1/4 DN32 OD	42.4	3.25	0.60	1.01	2182	76101	50734	25367	12684	10147	7610	5073		
1 1/2 DN40 OD	48.3	3.25	0.66	1.37	3255	113549	75700	37850	18925	15140	11355	7570		
2 DN50 OD	60.3	3.65	0.80	2.21	6365	222025	148017	74008	37004	29603	22203	14802		
TUBO DE COBRE / ACERO FINO														
10/1	10	1.00	0.40	0.05	72	2512	1674	837	419	335	251	167		
12/1	12	1.00	0.40	0.08	115	4019	2679	1340	670	536	402	268		
14/1	14	1.00	0.40	0.11	158	5526	3684	1842	921	737	553	368		
15/1	15	1.00	0.40	0.13	187	6530	4353	2177	1088	871	653	435		
16/1	16	1.00	0.40	0.15	216	7535	5023	2512	1256	1005	753	502		
18/1	18	1.00	0.40	0.20	288	10046	6698	3349	1674	1340	1005	670		
22/1	22	1.00	0.40	0.31	446	15572	10381	5191	2595	2076	1557	1038		
28/1	28	1.00	0.47	0.53	904	31522	21014	10507	5254	4203	3152	2101		
PER/ALU														
12/2	12	2.00	0.40	0.05	72	2512	1674	837	419	335	251	167		
14/2	14	2.00	0.40	0.08	115	4019	2679	1340	670	536	402	268		
16/1.5	16	1.50	0.40	0.13	187	6530	4353	2177	1088	871	653	435		
16/2	16	2.00	0.40	0.11	158	5526	3684	1842	921	737	553	368		
17/2	17	2.00	0.40	0.13	187	6530	4353	2177	1088	871	653	435		
18/2	18	2.00	0.40	0.15	216	7535	5023	2512	1256	1005	753	502		
20/2	20	2.00	0.40	0.20	288	10046	6698	3349	1674	1340	1005	670		
26/3	26	3.00	0.40	0.31	446	15572	10381	5191	2595	2076	1557	1038		
32/3	32	3.00	0.47	0.53	904	31522	21014	10507	5254	4203	3152	2101		
40/3.5	40	3.50	0.56	0.86	1726	60220	40147	20073	10037	8029	6022	4015		
50/4.25	50	4.25	0.66	1.35	3206	111824	74549	37275	18637	14910	11182	7455		
63/5	63	5.00	0.80	2.21	6346	221359	147573	73786	36893	29515	22136	14757		

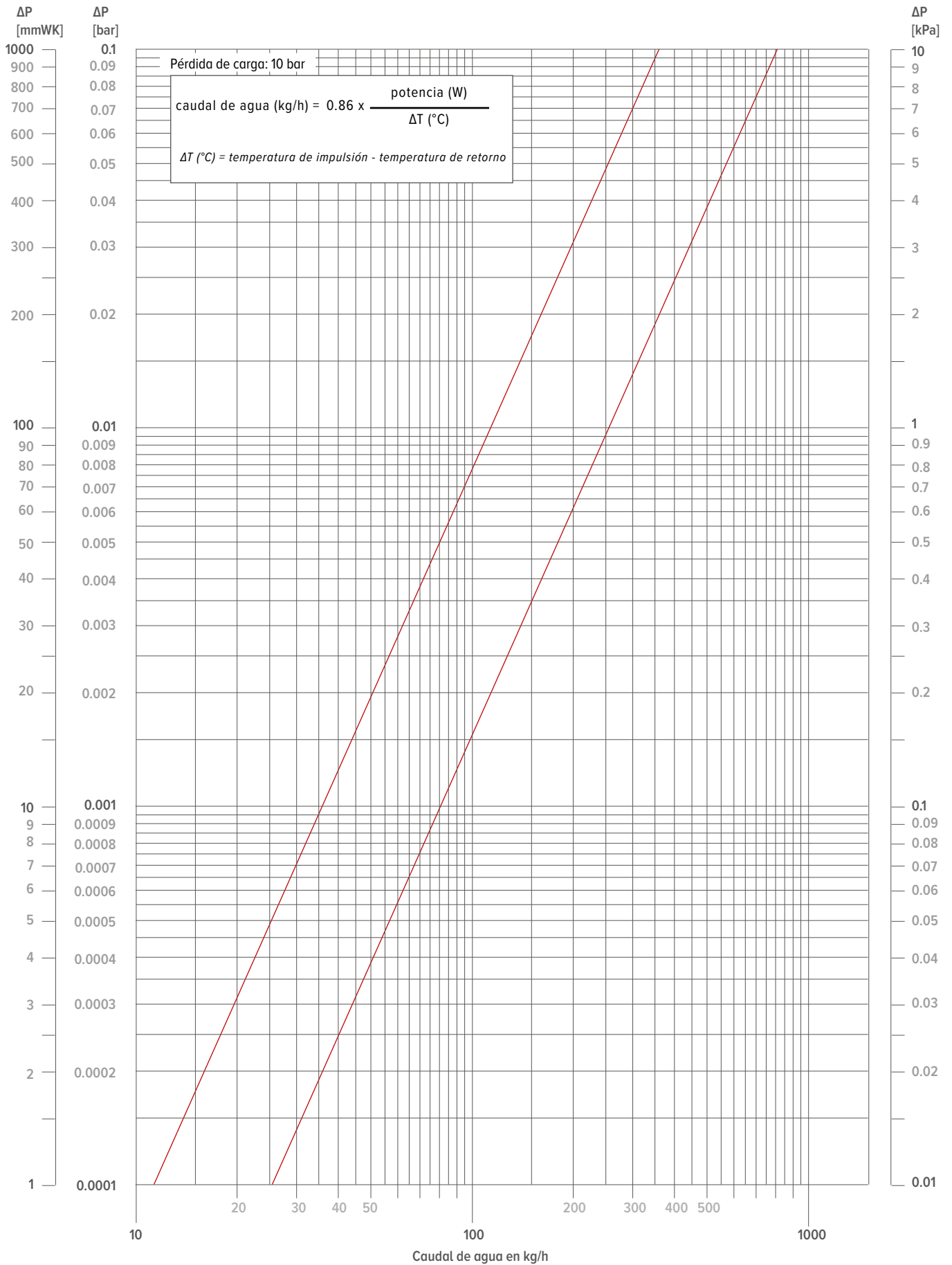

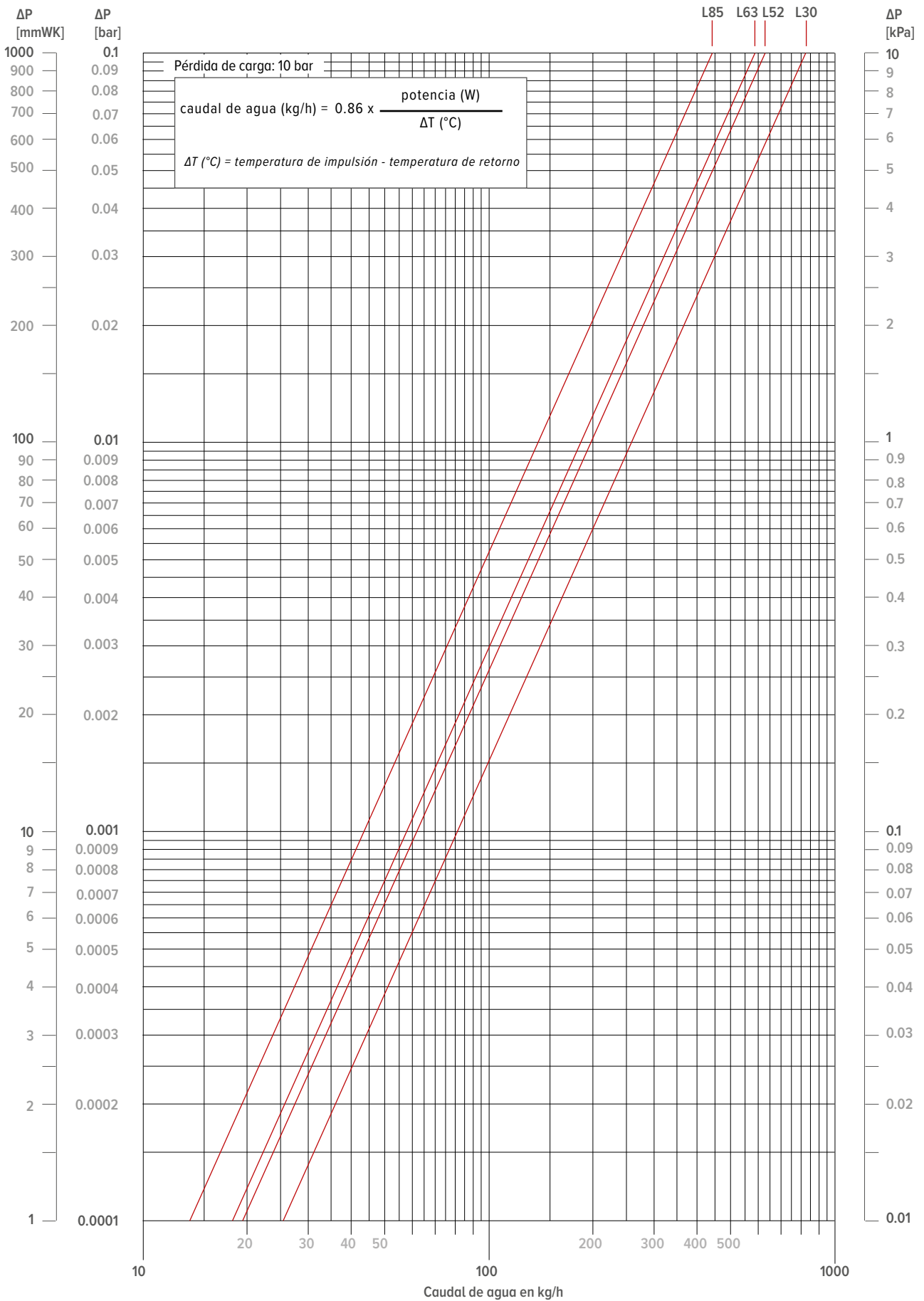

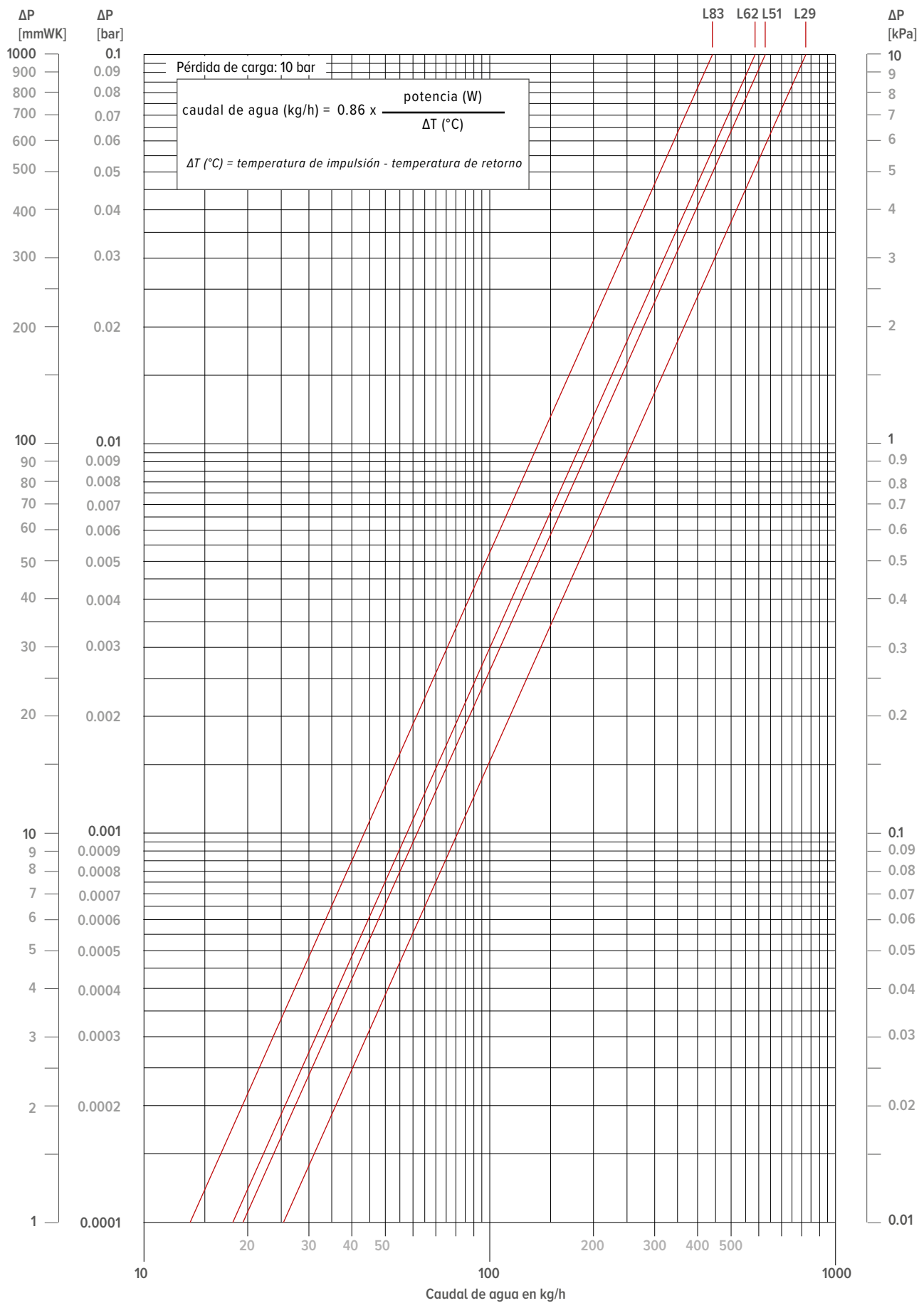

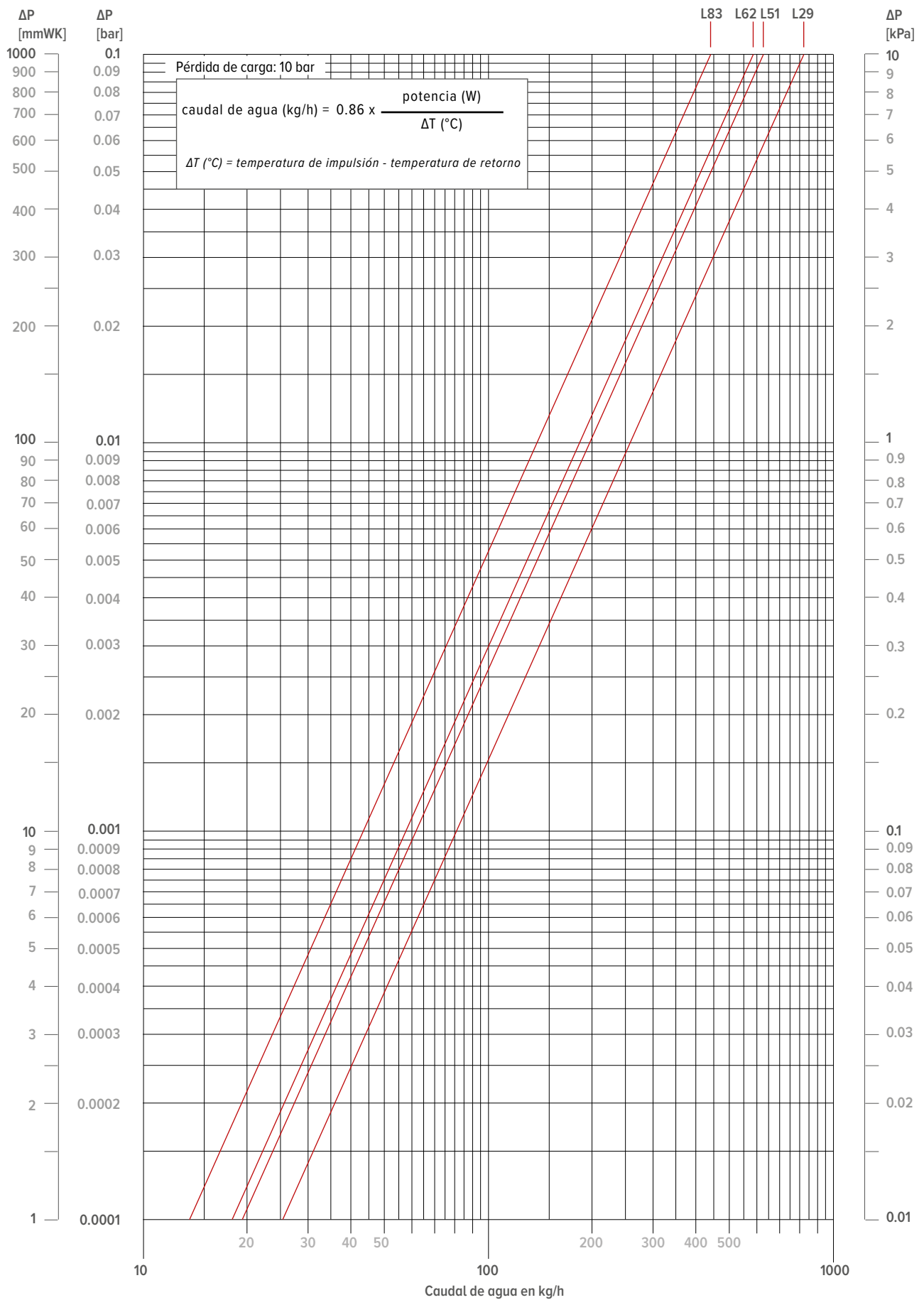

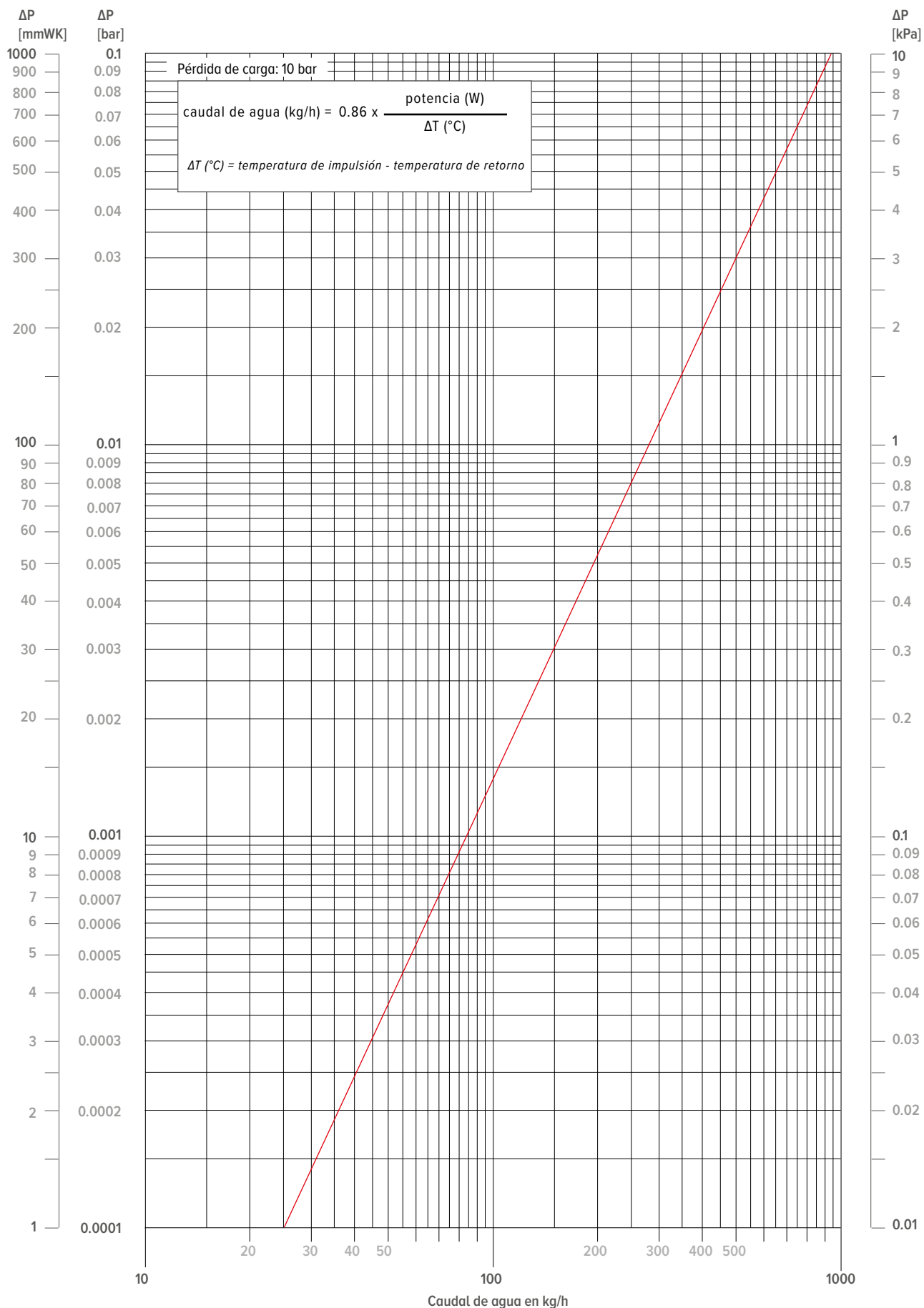

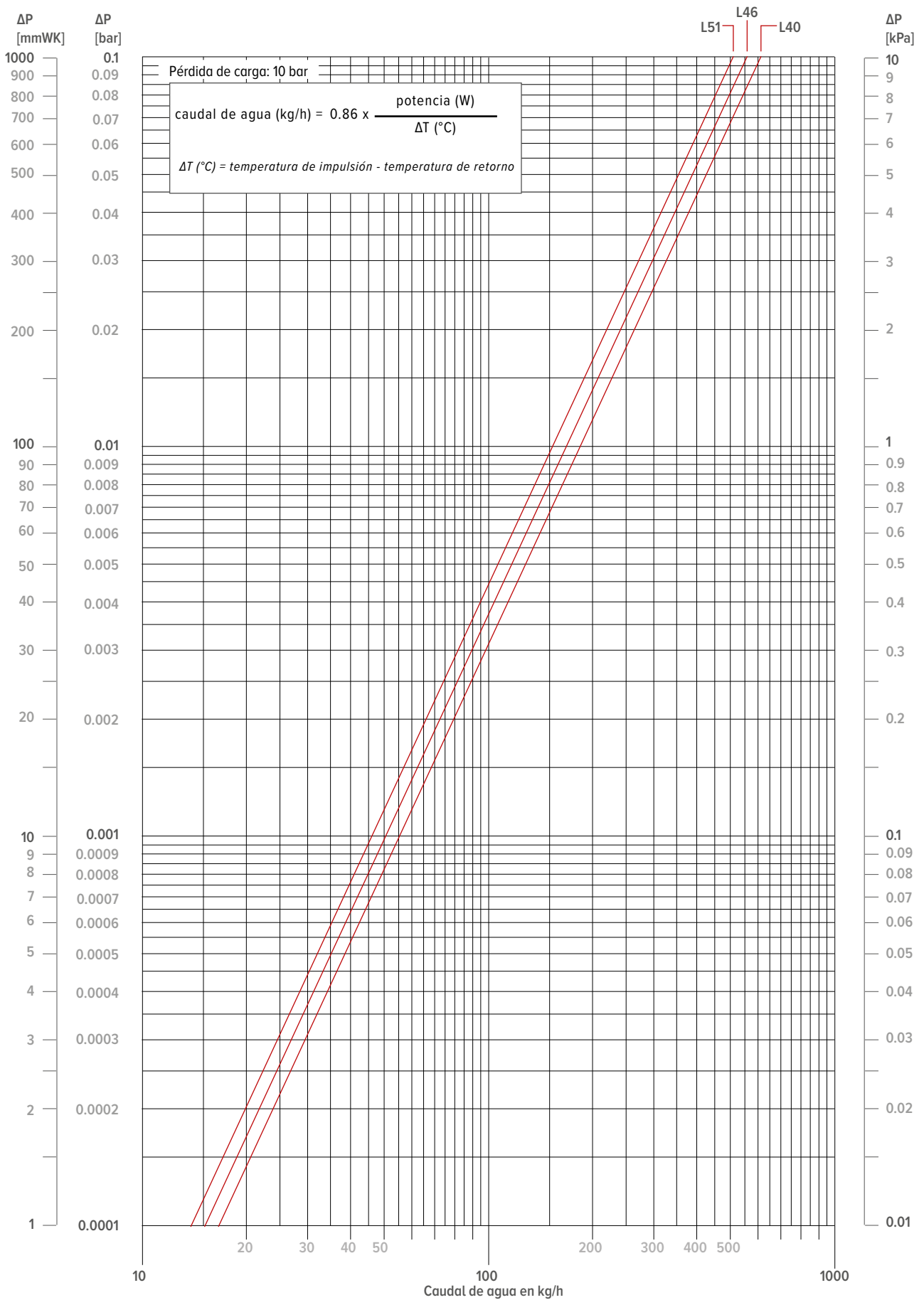



jaga CLIMATE
DESIGNERS

JAGA ESPAÑA CONVES TERMIC S.L.

¿Necesitas asesoramiento? ¡Consulta con nuestro departamento técnico!

+34 966 83 03 03
+34 673 5145 87

proyectos@conves.es
jaga.info
jagaventilacion.com

BÉLGICA JAGA NV

Verbindingslaan 16
3590 Diepenbeek

+32 (0) 11 29 41 11

info@jaga.be
jaga.com