



## VERTIGA HYBRID

The only vertical design radiators for super-low water temperatures





# VERTIGA HYBRID

<b>CONTENT</b>	<b>3</b>
<b>Overview</b>	<b>5</b>
<b>Dimensions</b>	<b>6</b>
<b>Standard delivery</b>	<b>6</b>
<b>Colours</b>	<b>6</b>
<b>Connection</b>	<b>6</b>
<b>Hydronic connection</b>	<b>7</b>
<b>Electrical connection</b>	<b>8</b>
Control: Jaga BMS (0-10V in) control	8
Control: Jaga 3 settings controller	8
<b>Which Jaga control system to choose</b>	<b>9</b>
<b>Technical table</b>	<b>10</b>
<b>Thermostats</b>	<b>11</b>
<b>Sample wire diagrams electrical installation</b>	<b>12</b>
Sample diagram 1	13
Sample diagram 2	14
Sample diagram 3	15
<b>Correction factors</b>	<b>16</b>
<b>Guideline for limiting flow noise</b>	<b>16</b>
<b>Pressure drop</b>	<b>17</b>
<b>Dew point air by air temperature and air humidity at air pressure 1013 hPa</b>	<b>18</b>

# VERTIGA HYBRID

## HEATING OR HEATING + LIGHT COOLING: THE IDEAL HEAT PUMP HEATING UNIT

### HIGH OUTPUT WITH ALL WATER TEMPERATURES, HOT AND COLD

For optimum yield, new, environmentally-friendly installations require an improved output system. This ensures a comfortable heat at a low water temperature and a sufficient coolness with non-condensing cooling. Jaga Hybrid heating units are equipped with the brand new DBH system; DB stands for Dynamic Boost, to considerably increase the power of the heater. The H of Hybrid stands for the dual effect: heating and cooling.

- perfectly controlled heating at the lowest water temperature thanks to the hybrid system's reaction speed
- by default, suitable for energy-efficient non-condensing cooling in combination with any heat pump

### MOST RESPONSIVE OUTPUT SYSTEM CRUCIAL FOR HEATING AND COOLING DOWN

#### HEATING

Is the oven or dishwasher on? If the sun shines inside? Your home is a dynamic given with constantly changing temperature conditions and comfort requirements. A quickly reacting heater such as Jaga Hybrid anticipates this and accurately controls the temperature in all circumstances.

#### NON-CONDENSING COOLING®

The reaction capacity is also crucial for non-condensing cooling. In order to prevent moisture problems, central condensation monitoring must be provided. This can only work efficiently with a very fast-acting delivery system, which immediately adjusts the cooling system in case of a sudden rise in humidity. More than ever, the responsiveness determines your energy consumption and your comfort.



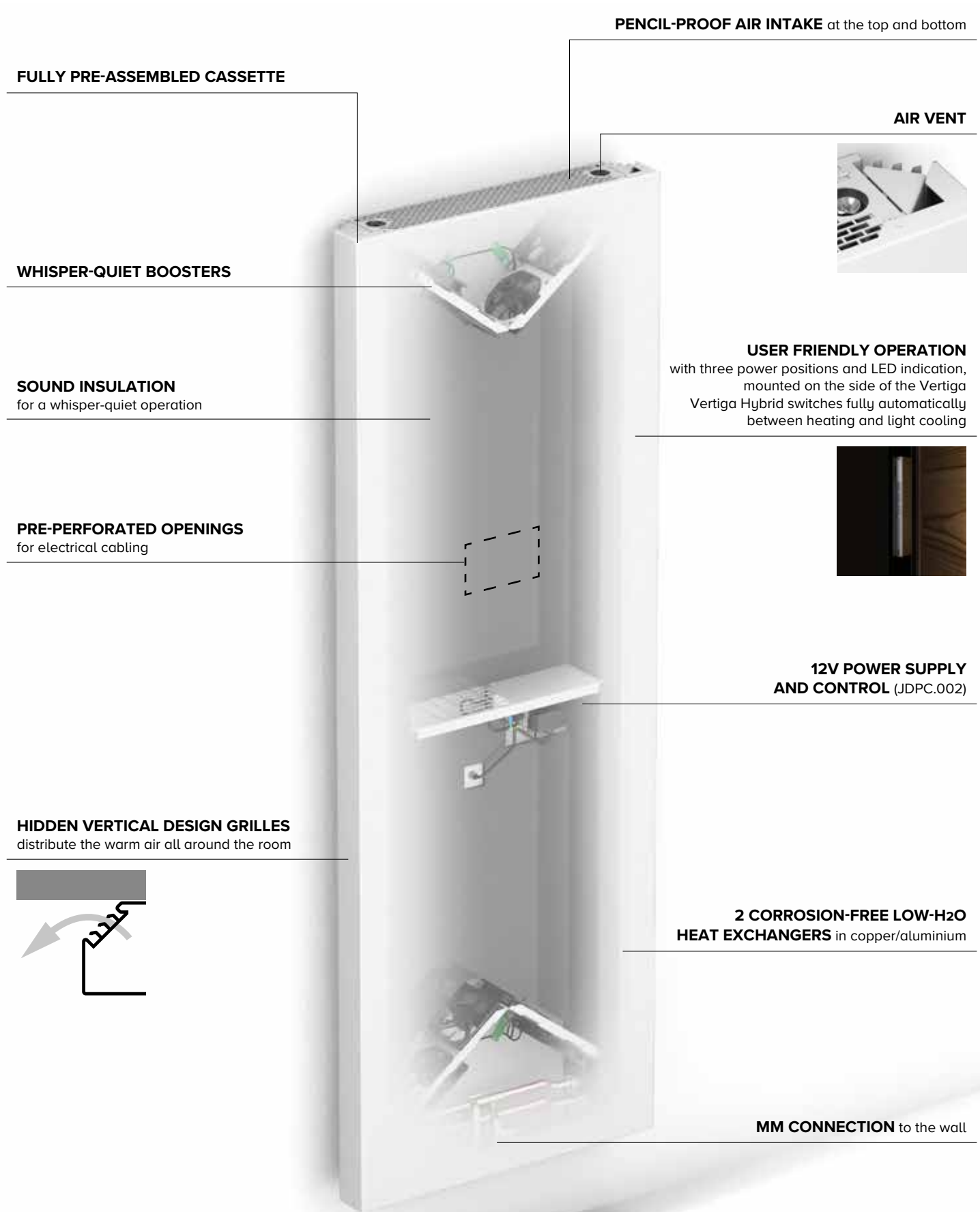

**PENCIL-PROOF AIR INTAKE** at the top and bottom

**FULLY PRE-ASSEMBLED CASSETTE**

**AIR VENT**



**WHISPER-QUIET BOOSTERS**

**SOUND INSULATION**  
for a whisper-quiet operation

**USER FRIENDLY OPERATION**  
with three power positions and LED indication,  
mounted on the side of the Vertiga  
Vertiga Hybrid switches fully automatically  
between heating and light cooling



**PRE-PERFORATED OPENINGS**  
for electrical cabling

**12V POWER SUPPLY  
AND CONTROL (JDPC.002)**

**HIDDEN VERTICAL DESIGN GRILLES**  
distribute the warm air all around the room

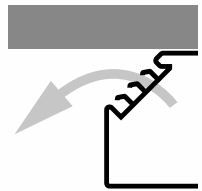

**2 CORROSION-FREE LOW-H<sub>2</sub>O  
HEAT EXCHANGERS** in copper/aluminium

**MM CONNECTION** to the wall

# VERTIGA HYBRID

DIMENSIONS (in mm)

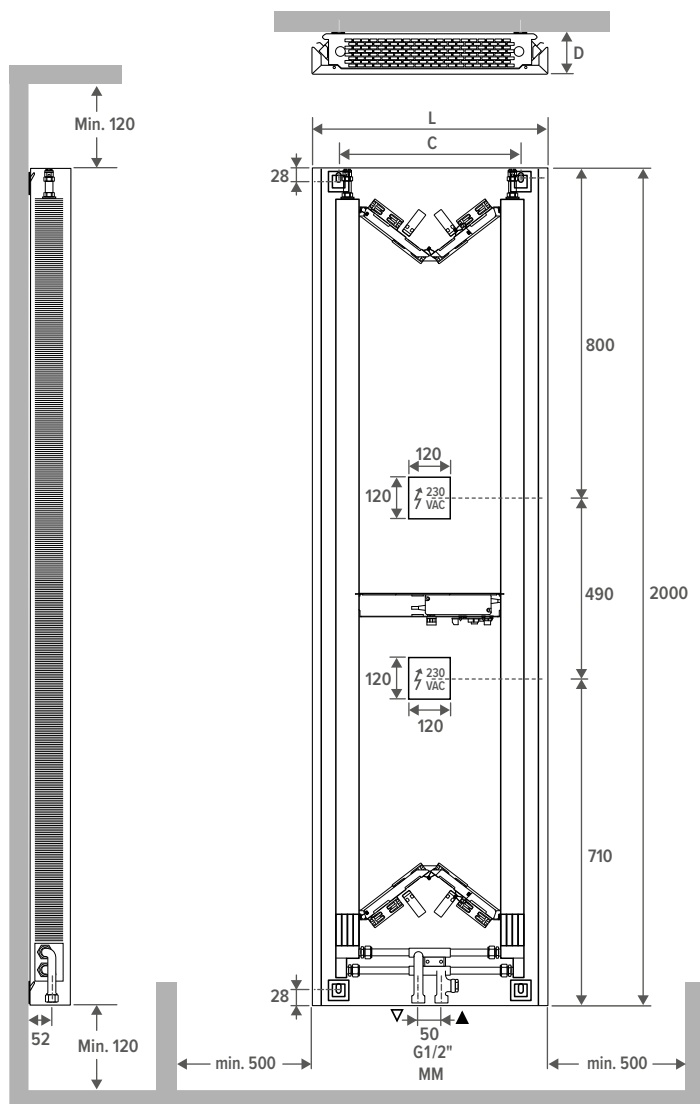

## ORDER CODE

VERW 200 041 08 XXX DDD

Control:

- Jaga 3 settings controller: D05
- Jaga BMS (0-10V in) control: D03

Colour

Type

Length

Height

## STANDARD DELIVERY

- front panel can be clicked in easily
- fully pre-assembled wall cassette with vertical grilles for air outlet at the left and right side
- pencil-proof intake openings on the top and bottom
- pre-perforated openings for electrical cabling
- central connection MM (MM Bottom or Top)

## COLOURS

### Standard colours

- traffic white RAL 9016 (133), soft touch lightly structured satin finish
- sandblast grey (001), fine texture metallic lak
- off-black (145), soft touch lightly-textured satin lacquer

### Other colours

see Jaga colour chart

## CONNECTION

### Standard

universal bottom connection MM, supply right

### Top connection

the radiator is symmetrical and can be mounted either way up, provide an air vent on the central heating pipework above the radiator

	TYPE 08			TYPE 12		
D	92			132		
L	410	520	650	530	700	900
C	206	316	446	278	448	648

# VERTIGA HYBRID

Multi-H valve (to the wall or to the floor)



set 143 pressure-independent flow control (0.01 - 0.34)

### Heating \*

COLO MHG AW 4...	AW	
COLO MHG AB 4...	AB	
COLO MHG AC 4...	AC	
COLO MHG JH 4...	JH	

### Heating and cooling

COLO MHG AW 5...	AW	
COLO MHG AB 5...	AB	
COLO MHG HC 5...	HC	

### Manual

COLO MHG MA 4...	MA	
------------------	----	--

fill in sleeve coupling code

### Sleeve couplings 3/4" Eurocone

PRECISION METAL TUBE		SYNTHETIC OR RPE/ALU	
CODE	Tube Ø	CODE	Tube Ø
112	12/1	612	12/2
114	14/1	614	14/2
115	15/1	616	16/2
116	16/1	618	18/2
118	18/1	619	16/1.5
		620	20/2

To the wall



set 41 2-pipe: KVS 1.65 one pipe: KVS: 2.20

### Heating \*

CODE PW3 AW 1...	AW	
CODE PW3 AB 1...	AB	
CODE PW3 AC 1...	AC	

### Heating and cooling

CODE PW3 HC 1...	HC	
------------------	----	--

### Manual

CODE PW3 MA 1...	MA	
------------------	----	--

fill in sleeve coupling code

### Sleeve coupling codes M24

PRECISION METAL TUBE		SYNTHETIC	
CODE	Tube Ø	CODE	Tube Ø
112	12/1	212	12/2
114	14/1	219	16/1.5
115	15/1	216	16/2
116	16/1	217	17/2
118	18/1	218	18/2

# HYDRONIC CONNECTION

To the floor

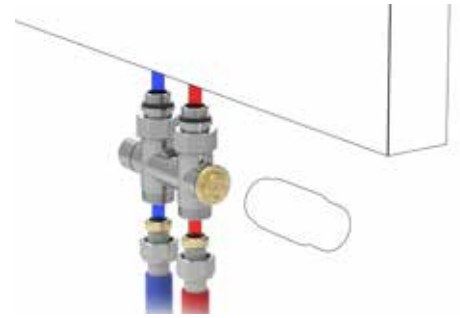

set 42 2-pipe: KVS 1.65 one pipe: KVS: 2.20

### Heating \*

CODE PF3 AW 1...	AW	
CODE PF3 AB 1...	AB	
CODE PF3 AC 1...	AC	

### Heating and cooling

CODE PF3 HC 1...	HC	
------------------	----	--

### Manual

CODE PF3 MA 1...	MA	
------------------	----	--

fill in sleeve coupling code

RPE/ALU		STEEL TUBE FOR C.H.	
CODE	Tube Ø	CODE	Tube Ø
314	14/2	501	M24 x 1/2"
316	16/2	503	M24 x 3/8"
326	16/2.2		
318	18/2		

## JAGA CONTROLS



TYPE	POSITION	CONTROL PANEL	EXTERNAL 0-10 V CONTROL	2-PIPE	WATER TEMPERATURE SENSOR	AIR TEMPERATURE SENSOR
Jaga BMS (0-10V in) control (D05)	 	-	✓	✓	✓	-
Jaga 3 settings controller (D03)	 	✓	-	✓	✓	-



### NO JAGA CONTROL SYSTEM

- Upon request for heating or cooling, a BMS/home automation system or a JAGA thermostat will open the thermoelectric valve.
- Upon request for cold or heat, a BMS/home automation system or a JAGA thermostat will send a 0-10 VDC signal. The fan will rotate proportionally to the 0-10 VDC signal.

### JAGA BMS 0-10V CONTROL

- Upon request for heating or cooling, a BMS/home automation system or a JAGA thermostat will open the thermoelectric valve.
- When heating or cooling is requested, a BMS/home automation system or JAGA thermostat will transmit a 0-10V signal.
- When the fan recognises cold (<18°C) or hot (>28°C) water, it will rotate proportionally of the 0-10 V signal.

### JAGA 3 SETTINGS CONTROLLER

- When heat or cold is requested, an external signal (thermostat, BMS/home automation, ...) a thermal engine.
- Heating: The fan will rotate at a fixed speed once the water has reached the setting of 28°C.
- Cooling: he fan will rotate at a fixed speed once the water has reached the setting of 18°C.
- The user manually selects the desired mode via the control panel  /  / OFF. The unit can run at 3 speeds. The unit starts at the last selected speed(1, 2 or 3) when the preset water temperature is reached.

**Unit without integrated room temperature control**  
 Fans will start automatically when the external control sends warm/ cold water through the radiator

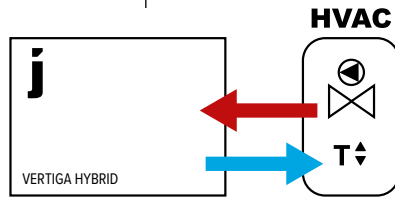

- Without 0-10V signal:
- room thermostat (None-Jaga)
  - area control with room temperature control
  - boiler or heat pump control with room temperature control
  - home automation with room temperature control
  - other external room temperature controls

- 0-10V signal for fan control available from
- (Jaga) room thermostat with 0-10V signal to unit
  - home automation with 0-10V signal to unit

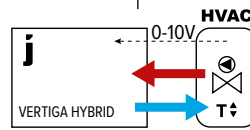
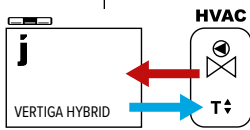

Choose 1 of 3 fan speeds  
 (speed will not adjust, depending on room temperature)

Fan speed is controlled by 0-10V connection to the electronics in the radiator

Fan speed is controlled by 0-10V connection to electronics outside the radiator

**JAGA 3 SETTINGS CONTROLLER**

**JAGA BMS**

**NO CONTROL SYSTEM**

Coding:

D05

D03

/

# VERTIGA HYBRID

	HEIGHT H cm	LENGTH L cm	TYPE T	POSITION	COOLING (non-condensing) Room temperature 27°C	HEATING Room temperature 20°C					SOUND PRESSURE LEVEL dB(A)	POWER CONSUMPTION Watts	ORDER CODE
					16/18 Watts	35/30 Watts	45/40 Watts	50/45 Watts	55/45 Watts	75/65 Watts			
VERW	200	041	08	1	127	325	591	724	784	1315	26.0	8.1	VERW 200 041 08 XXX DDD
				2	154	359	652	797	864	1449	30.0	8.7	
				3	178	401	728	892	966	1620	33.3	9.0	
		052	08	1	151	353	642	786	852	1428	26.0	10.1	VERW 200 052 08 XXX DDD
				2	180	404	734	899	974	1633	30.0	10.9	
				3	237	566	1029	1260	1365	2289	36.6	13.1	
		065	08	1	180	406	738	903	979	1641	26.0	10.6	VERW 200 065 08 XXX DDD
				2	210	463	842	1030	1116	1872	30.0	13.6	
				3	304	753	1368	1674	1814	3042	39.9	17.8	
200	053	12	1	527	613	1114	1227	1364	1892	26.0	4.5	VERW 200 053 12 XXX DDD	
			2	756	850	1545	1701	1891	2624	30.0	6.0		
			3	932	1049	1907	2099	2334	3238	38.7	8.0		
		070	12	1	796	926	1682	2059	2231	3741	26.0	9.5	VERW 200 070 12 XXX DDD
				2	1075	1208	2196	2687	2912	4883	30.0	12.0	
				3	1290	1453	2640	3231	3501	5871	40.8	16.0	
		090	12	1	982	1167	2120	2594	2811	4714	26.0	13.0	VERW 200 090 12 XXX DDD
				2	1390	1489	2705	3311	3588	6016	30.0	17.0	
				3	1703	1772	3219	3940	4270	7159	42.9	24.0	

Output measured in accordance with EN 16430

\*Noise measurement according to ISO 3741:2010, at a 2-m distance from the unit and with an assumed room attenuation of 8 dB(A)/room volume 100 m<sup>3</sup> / reverberation time 0.5 sec.

Enter colour code |  
Enter control system code |

**JRT-100 TB**  
BLACK



8751 050019

**JRT-100 TW**  
WHITE



8751 050017

**JRT-200 W**



8751 050021

**RDG 260T**



8751 050020

**RDG264KN**



8751 050018

	<b>JRT-100 TB</b>	<b>JRT-100 TW</b>	<b>JRT-200 W</b>	<b>RDG 260T</b>	<b>RDG264KN</b>
<b>POWER SUPPLY</b>					
supply voltage	24V DC	24V DC	24V DC	24V DC	24V DC
<b>OUTPUT / INPUT VOLTAGE</b>					
valve 24V DC contact	2 (NO)	2 (NO)	2	-	-
potential-free contact	-	-	-	3 (NO)	3 (NO)
input from keycard	-	-	-	✓	✓
input from window contact	-	-	-	✓	✓
fan (0 - 10 V DC)	max. +/- 10 mA	max. +/- 10 mA	max. +/- 10 mA	max. +/- 5 mA	max. +/- 5 mA
manual 3-position speed controller	✓	✓	✓	✓	✓
automatic mode	✓	✓	✓	✓	✓
<b>APPLICATIONS</b>					
2-pipe					
manual (H/C)	✓	✓	✓	✓	✓
auto (H/C) - water temperature sensor required	-	-	-	✓	✓
4-pipe					
manual (H/C)	✓	✓	✓	✓	✓
auto (H/C)	✓	✓	✓	✓	✓
<b>DIMENSIONS</b>					
for wall-mounting	-	-	✓	✓	✓
for recessed-mounting	✓	✓	optional	optional	optional
<b>POSITION</b>					
LCD display with backlight	-	-	✓	✓	✓
LCD touch screen with backlight	✓	✓	-	-	-
protection category IP20	-	-	✓	-	-
protection category IP30	✓	✓	-	✓	✓
integrated CO2-sensor	-	-	-	-	✓
humidity sensor	-	-	-	-	✓
<b>FEATURES</b>					
programmable time zones	✓	✓	✓	✓	✓
control via Wi-Fi (smartphone app)	✓	✓	✓	-	-
fan start delay	-	-	-	✓	✓
continuous fan speed	-	-	-	✓	✓
temperature sensor 80 cm	✓	✓	optional	optional	optional

With these template schedules for thermostat or home automation systems, Jaga strives to simplify the installation process for you. Make sure to perfectly align power supply, thermostatic valve mounting, controls, pipe system, temperature monitoring and number of units per area.

Here, you can find the most common combinations. Feel free to ask for more variations at [info@jaga.com](mailto:info@jaga.com)

## 1. POWER SUPPLY

**Option 1:** integrated power supply (inside the unit)

**Option 2:** power supply DIN-rail assembly (outside the unit)

## 2. THERMOSTATIC VALVE

**Option 1:** on the collector (outside the unit)

## 3. CHOICE OF THERMOSTAT

**Option 1:** thermostat JRT-100TW

**Option 2:** thermostat JRT-100

**Option 3:** thermostat JRT-200

**Option 4:** thermostat RDG160T

**Option 5:** home automation

## 4. HYDRONIC

**Option 1:** 2-pipe system

## 5. TEMPERATURE MONITORING

**Option 1:** with temperature monitoring

## 6. UNITS / ZONE

**Option 1:** one unit

**Option 2:** multiple units

# VERTIGA HYBRID

# SAMPLE DIAGRAM 1

- integrated power supply
- thermostatic valve on the collector
- BMS
- 2-pipe
- temperature monitoring
- 1 unit per area

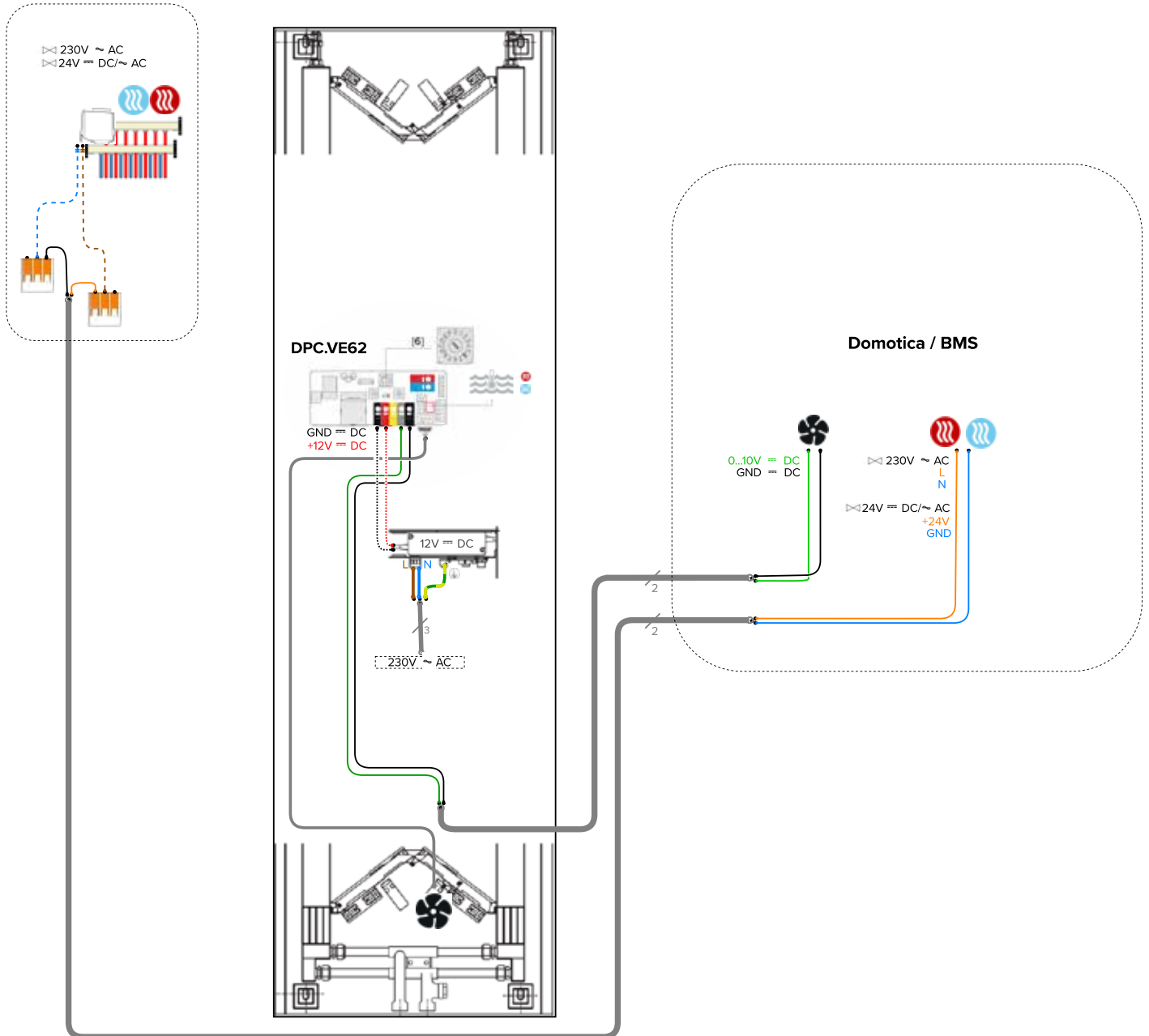

- power supply DIN-rail assembly
- thermostatic valve on the collector
- JRT100TW
- temperature monitoring
- 2-pipe
- JDPC
- 1 unit per area

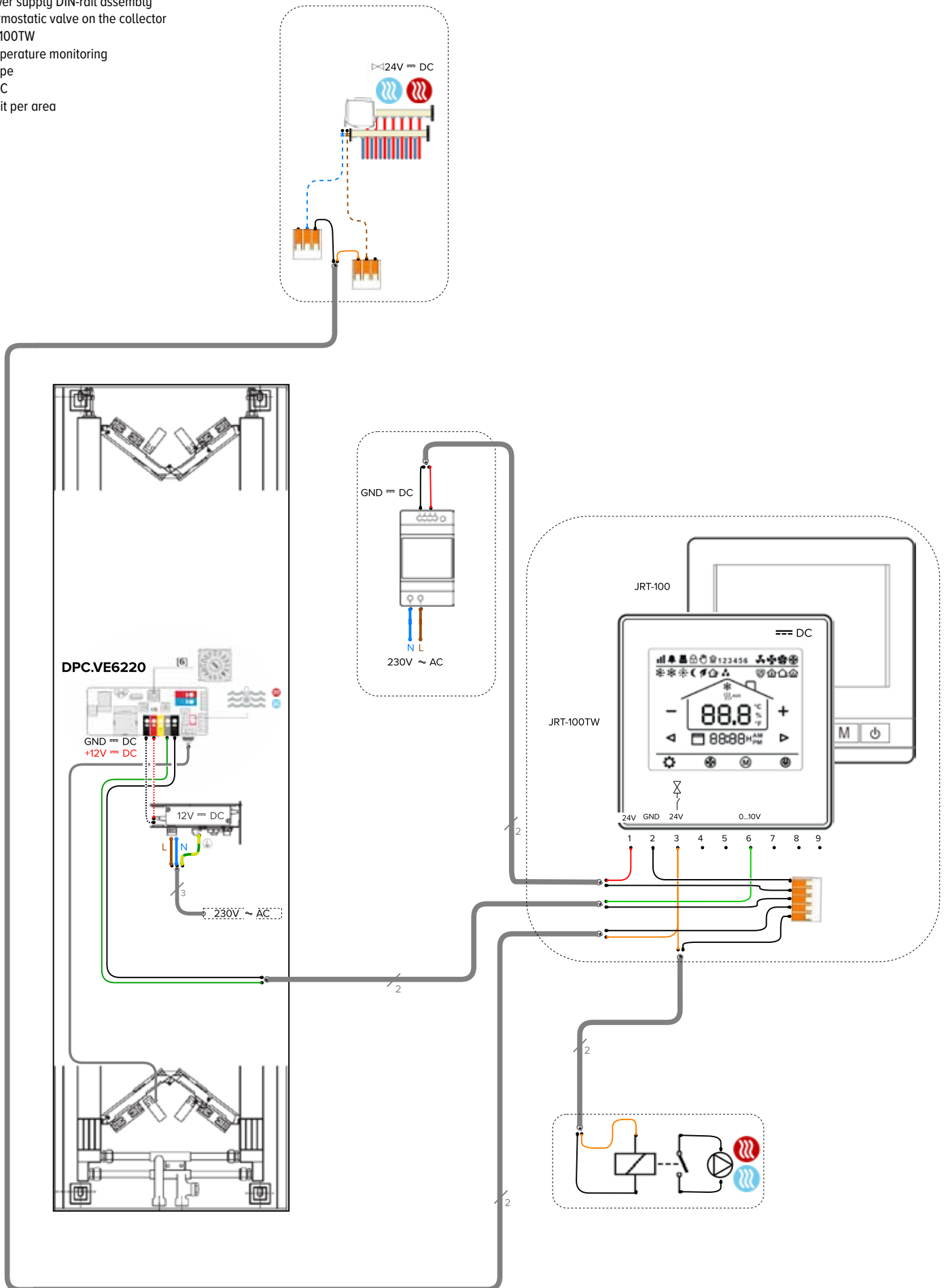

# VERTIGA HYBRID

# SAMPLE DIAGRAM 3

- integrated power supply
- thermostatic valve inside the unit
- BMS
- 2-pipe
- temperature monitoring
- JDPC
- 1 unit per area

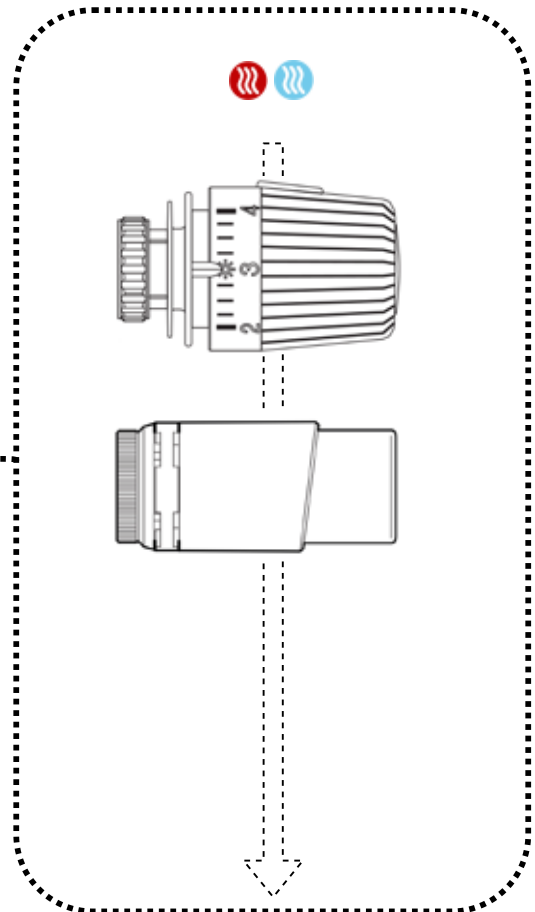
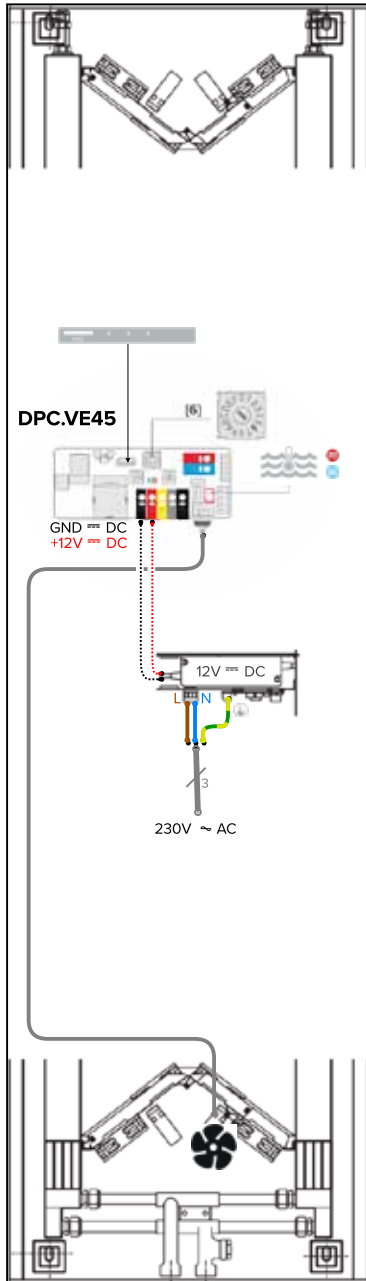

The indicated outputs at  $\Delta T$  50 are exact values measured in accordance with EN16430. This table provides a calculated value using an average correction factor for all other  $\Delta T$  outputs, valid for all dimensions.

Click [www.jaga.com/selection-tools/](http://www.jaga.com/selection-tools/) to download the calculation tools with the exact outputs. The online calculation tools are kept up to date with the most recent data. Minor output differences between printed tables and the different online calculation tools are therefore completely normal and within the margins of tolerance imposed by the standard.

## AVERAGE CORRECTION FACTORS DYNAMIC PRODUCTS - 75/65/20°C

room temperature: 20°C Average N-value: 1.00

TA	TR	65	60	55	50	45	40	35	30	25
75	1.00	0.95	0.89	0.83	0.76	0.69	0.62	0.53	0.42	
70	0.95	0.90	0.84	0.79	0.72	0.66	0.58	0.50	0.39	
65		0.85	0.80	0.74	0.68	0.62	0.55	0.47	0.37	
60			0.75	0.70	0.64	0.58	0.51	0.43	0.34	
55				0.65	0.60	0.54	0.47	0.40	0.31	
50					0.55	0.49	0.43	0.37	0.28	
45						0.45	0.39	0.33	0.25	
40							0.35	0.29	0.22	
35								0.25	0.18	
30									0.14	

room temperature: 24°C Average N-value: 1.00

TA	TR	65	60	55	50	45	40	35	30	25
75		0.92	0.86	0.81	0.74	0.68	0.61	0.52	0.42	0.26
70		0.87	0.82	0.76	0.70	0.64	0.57	0.49	0.39	0.24
65			0.77	0.72	0.66	0.60	0.53	0.46	0.37	0.22
60				0.67	0.62	0.56	0.49	0.42	0.34	0.20
55					0.57	0.52	0.46	0.39	0.31	0.18
50						0.47	0.41	0.35	0.27	0.15
45							0.37	0.31	0.24	0.13
40								0.27	0.20	0.11
35									0.17	0.08
30										0.06

## GUIDELINE FOR LIMITING FLOW NOISE

TUBE	outer $\emptyset$ mm	Wall thick- ness mm	Max. water speed (EN10255) m/s	water content per metre l	max. water flow kg/h	Maximum power at $\Delta T$ (° C) (T supply - T return)						
						$\Delta T$ 30 Watts	$\Delta T$ 20 Watts	$\Delta T$ 10 Watts	$\Delta T$ 5 Watts	$\Delta T$ 4 Watts	$\Delta T$ 3 Watts	$\Delta T$ 2 Watts
<b>GALVANISED PIPE DIN 2440</b>												
3/8 DN10 OD	17.2	2.35	0.40	0.12	173	6028	4019	2009	1005	804	603	402
1/2 DN15 OD	21.3	2.65	0.40	0.20	288	10046	6698	3349	1674	1340	1005	670
3/4 DN20 OD	26.9	2.65	0.42	0.37	559	19515	13010	6505	3253	2602	1952	1301
1 DN25 OD	33.7	3.25	0.49	0.58	1023	35690	23793	11897	5948	4759	3569	2379
1 1/4 DN32 OD	42.4	3.25	0.60	1.01	2182	76101	50734	25367	12684	10147	7610	5073
1 1/2 DN40 OD	48.3	3.25	0.66	1.37	3255	113549	75700	37850	18925	15140	11355	7570
2 DN50 OD	60.3	3.65	0.80	2.21	6365	222025	148017	74008	37004	29603	22203	14802
<b>PRECISION METAL TUBE</b>												
10/1	10	1.00	0.40	0.05	72	2512	1674	837	419	335	251	167
12/1	12	1.00	0.40	0.08	115	4019	2679	1340	670	536	402	268
14/1	14	1.00	0.40	0.11	158	5526	3684	1842	921	737	553	368
15/1	15	1.00	0.40	0.13	187	6530	4353	2177	1088	871	653	435
16/1	16	1.00	0.40	0.15	216	7535	5023	2512	1256	1005	753	502
18/1	18	1.00	0.40	0.20	288	10046	6698	3349	1674	1340	1005	670
22/1	22	1.00	0.40	0.31	446	15572	10381	5191	2595	2076	1557	1038
28/1	28	1.00	0.47	0.53	904	31522	21014	10507	5254	4203	3152	2101
<b>RPE/ALU</b>												
12/2	12	2.00	0.40	0.05	72	2512	1674	837	419	335	251	167
14/2	14	2.00	0.40	0.08	115	4019	2679	1340	670	536	402	268
16/1.5	16	1.50	0.40	0.13	187	6530	4353	2177	1088	871	653	435
16/2	16	2.00	0.40	0.11	158	5526	3684	1842	921	737	553	368
17/2	17	2.00	0.40	0.13	187	6530	4353	2177	1088	871	653	435
18/2	18	2.00	0.40	0.15	216	7535	5023	2512	1256	1005	753	502
20/2	20	2.00	0.40	0.20	288	10046	6698	3349	1674	1340	1005	670
26/3	26	3.00	0.40	0.31	446	15572	10381	5191	2595	2076	1557	1038
32/3	32	3.00	0.47	0.53	904	31522	21014	10507	5254	4203	3152	2101
40/3.5	40	3.50	0.56	0.86	1726	60220	40147	20073	10037	8029	6022	4015
50/4.25	50	4.25	0.66	1.35	3206	111824	74549	37275	18637	14910	11182	7455
63/5	63	5.00	0.80	2.21	6346	221359	147573	73786	36893	29515	22136	14757

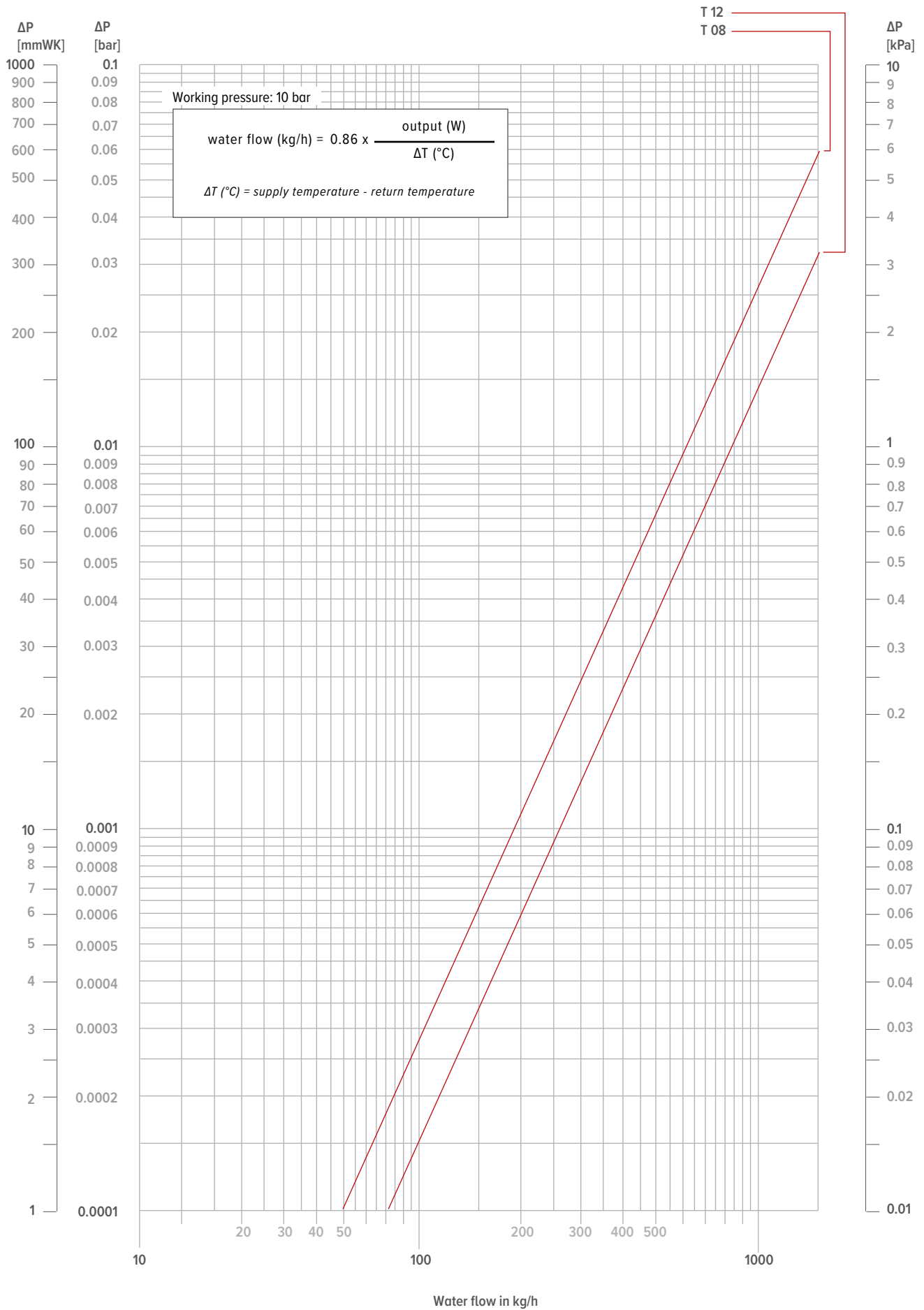

## VERTIGA HYBRID

### DEW POINT AIR BY AIR TEMPERATURE AND AIR HUMIDITY AT AIR PRESSURE 1013 HPA MINIMUM WATER TEMPERATURE FOR NON-CONDENSING COOLING

AIR TEMPERATURE (°C)	RELATIVE AIR HUMIDITY (%)					
	40	50	60	70	80	90
20	6.0	9.3	12.0	14.4	16.4	18.3
21	6.9	10.2	12.9	15.3	17.4	19.3
22	7.8	11.1	13.9	16.3	18.4	20.3
23	8.7	12.0	14.8	17.2	19.4	21.3
24	9.6	12.9	15.8	18.2	20.3	22.3
25	10.5	13.9	16.7	19.1	21.3	23.2
26	11.4	14.8	17.6	20.1	22.3	24.2
27	12.2	15.7	18.6	21.1	23.3	25.2
28	13.1	16.6	19.5	22.0	24.2	26.2
29	14.0	17.5	20.4	23.0	25.2	27.2
30	14.9	18.4	21.4	23.9	26.2	28.2
31	15.8	19.4	22.3	24.9	27.1	29.2
32	16.7	20.3	23.3	25.8	28.1	30.2
33	17.6	21.2	24.2	26.8	29.1	31.1
34	18.5	22.1	25.1	27.8	30.1	32.1
35	19.4	23.0	26.1	28.7	31.0	33.1

If a unit is not equipped with a connected condensate drain, it must be ensured that condensation does not form on the heat exchanger within the unit. This is particularly applicable to Jaga 'non-condensing cooling' units. To prevent condensation, the water temperature must be higher than the dew point of the air in which the unit operates. This table shows the minimum water temperature required for a unit to function without condensation forming.



**jaga**

CLIMATE  
DESIGNERS

**JAGA INTERNATIONAL JAGA NV**

In need of some advice? Make an appointment at the Jaga Advice Centre.

Verbindingslaan 16  
3590 Diepenbeek

+32 (0) 11 29 41 12

export@jaga.be  
jaga.com